

## Adjustable Precision Shunt Regulator

### Features

- **Precise Reference Voltage to 2.500V**
- **Guaranteed 0.5%, 1% or 2% Reference Voltage Tolerance**
- **Sink Current Capability, 1mA to 100mA**
- **Quick Turn-On**
- **Adjustable Output Voltage,  $V_o = V_{REF}$  to 20V**
- **Low Operational Cathode Current, 250 $\mu$ A Typical**
- **0.1W Typical Output Impedance**
- **SOT-23-3, SOT-23-5, SOT-89, SOP-8, and TO-92 Packages**
- **Lead Free and Green Devices Available (RoHS Compliant)**

### General Description

The APL431 is a 3-terminal adjustable voltage reference with specified thermal stability over applicable commercial temperature ranges. Output voltage may be set to any value between  $V_{REF}$  (2.5 V) and 20 V with two external resistors (See Figure 2). When used with an photocoupler, the APL431 is an ideal voltage reference in isolated feedback circuits for 2.5V to 12V switching-mode power supplies. This device has a typical output impedance of 0.1 $\Omega$ . Active output circuitry provides a very sharp turn-on characteristic, making the APL431 excellent replacements for zener diodes in many applications, including on-board regulation and adjustable power supplies.

### Applications

- **Linear Regulators**
- **Adjustable Power Supply**
- **Switching Power Supply**

### Pin Configuration

### Symbol

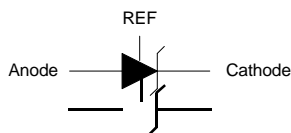

### Functional Diagram

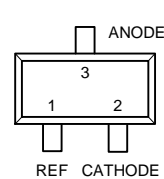
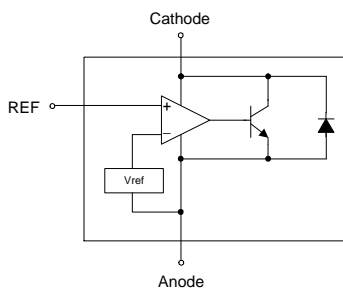

SOT-23-3 (Top View)

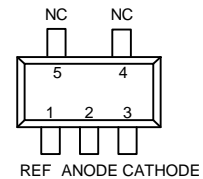

SOT-23-5 (Top View)

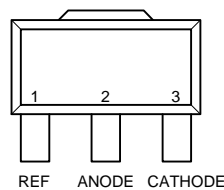

SOT-89 (Top View)

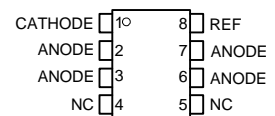

SOP-8 (Top View)

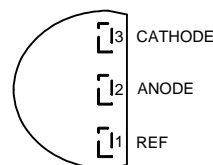

TO-92 (Top View)

ANPEC reserves the right to make changes to improve reliability or manufacturability without notice, and advise customers to obtain the latest version of relevant information to verify before placing orders.

## Ordering and Marking Information

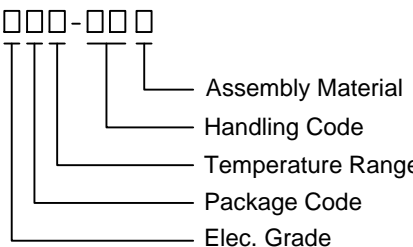
<p>APL431    □□□-□□□</p>  <p>Assembly Material Handling Code Temperature Range Package Code Elec. Grade</p>	<p>Elec. Grade A : 0.5% Reference Voltage Tolerance B : 1% Reference Voltage Tolerance C : 2% Reference Voltage Tolerance</p> <p>Package Code A : SOT-23-3    B : SOT-23-5    D : SOT-89 E : TO-92       K : SOP-8       Y : Chip Form</p> <p>Operating Ambient Temperature Range C : 0 to 70 °C    I : -40 to 85 °C</p> <p>Handling Code TB : Tape &amp; Box    TR : Tape &amp; Reel PB : Plastic &amp; Box</p> <p>Assembly Material G : Halogen and Lead Free Device</p>	
APL431 A/B :	431	
APL431 D :	APL431 XXXXX	XXXXX - Date Code
APL431 E :	APL 431 XXXXX	XXXXX - Date Code
APL431 K :	APL431 XXXXX	XXXXX - Date Code

Note: ANPEC lead-free products contain molding compounds/die attach materials and 100% matte tin plate termination finish; which are fully compliant with RoHS. ANPEC lead-free products meet or exceed the lead-free requirements of IPC/JEDEC J-STD-020C for MSL classification at lead-free peak reflow temperature. ANPEC defines "Green" to mean lead-free (RoHS compliant) and halogen free (Br or Cl does not exceed 900ppm by weight in homogeneous material and total of Br and Cl does not exceed 1500ppm by weight).

## Absolute Maximum Ratings (Note 1)

Symbol	Parameter	Rating	Unit
V <sub>KA</sub>	Cathode Voltage	21	V
I <sub>K</sub>	Continuous Cathode Current Range	100	mA
I <sub>REF</sub>	Reference Current Range	3	mA
T <sub>A</sub>	Ambient Temperature Range	APL431XXC APL431XXI 0 to 70 -40 to 85	°C
T <sub>J</sub>	Junction Temperature Range	APL431XXC APL431XXI 0 to 150 -40 to 150	°C
T <sub>STG</sub>	Storage Temperature Range	-65 to 150	°C
T <sub>SOL</sub>	Maximum Lead Soldering Temperature, 10 Seconds	260	°C

Note 1: Absolute Maximum Ratings are those values beyond which the life of a device may be impaired. Exposure to absolute maximum rating conditions for extended periods may affect device reliability.

## Thermal Characteristics

Symbol	Parameter	Typical Value	Unit	
$\theta_{JA}$	Thermal Resistance from Junction to Ambient in Free Air <sup>(Note 2)</sup>		°C/W	
		SOT-23		416
		SOT-23-5		357
		SOT-89		250
		TO-92		250
	SOP-8	210		

Note 2:  $\theta_{JA}$  is measured with the component mounted on a high effective thermal conductivity test board in free air.

## Electrical Characteristics $T_A = 25^\circ\text{C}$ ( unless otherwise noted)

Symbol	Parameter	Test Conditions	APL431			Unit	
			Min.	Typ.	Max.		
$V_{REF}$	Reference Voltage	$V_{KA}=V_{REF}, I_K=10\text{mA}$ <sup>(Note 3)</sup>	APL431A	2.487	2.500	2.513	V
			APL431B	2.475	2.500	2.525	
			APL431C	2.450	2.500	2.550	
$\Delta V_{REF} / T$	Reference Voltage Drift Over Temperature Range	$V_{KA}=V_{REF}, I_K=10\text{mA}$ $T_A = 0 \text{ to } 70^\circ\text{C}$ <sup>(Note 3)</sup> $T_A = -40 \text{ to } 85^\circ\text{C}$ <sup>(Note 3)</sup>	-	-	20 30	mV	
$\Delta V_{REF} / \Delta V_{KA}$	Voltage Ratio (Open Loop Gain)	$I_K=10\text{mA}, V_{KA}=V_{REF}$ to 10V <sup>(Note 4)</sup>	-	-1.5	-3	mV/V	
		$I_K=10\text{mA}, V_{KA}=V_{REF}$ to 20V <sup>(Note 4)</sup>	-	-1.2	-2.5		
$I_{REF}$	Reference Current	$I_K=10\text{mA}, R_1=10\text{k}\Omega, R_2=\text{open}$ <sup>(Note 4)</sup>	-	1.0	3	$\mu\text{A}$	
$\Delta I_{REF}/T$	Reference Current Drift	$I_K=10\text{mA}, R_1=10\text{k}\Omega, R_2=\text{open},$ $T_A = -40 \text{ to } 85^\circ\text{C}$ <sup>(Note 4)</sup>	-	0.3	1	$\mu\text{A}$	
$I_{K(\text{min})}$	Min. Cathode Current	$V_{KA}=V_{REF}$ <sup>(Note 3)</sup>	-	0.25	0.5	mA	
$I_{K(\text{off})}$	Off-state Cathode Current	$V_{KA}=20\text{V}, V_{REF}=0\text{V}$ <sup>(Note 5)</sup>	-	0.1	1	$\mu\text{A}$	
$ Z_{KA} $	Dynamic Impedance	$V_{KA}=V_{REF}$ $I_K=1\text{mA to } 100\text{mA}, f \leq 1\text{kHz}$ <sup>(Note 3)</sup>	-	0.1	0.4	$\Omega$	
$I_K$	Cathode Current		-	-	100	mA	

Note 3 : use Figure 1

Note 4 : use Figure 2

Note 5 : use Figure 3

## Test Figures

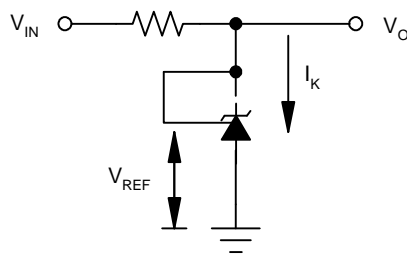

Figure 1. Test Circuit for  
 $V_{KA}=V_{REF}, V_O=V_{KA}=V_{REF}$

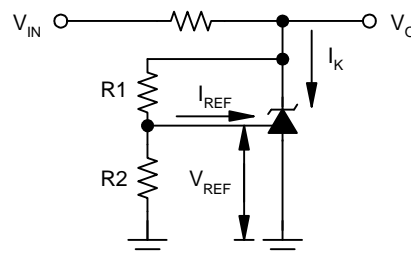

Figure 2. Test Circuit for  
 $V_{KA} > V_{REF}, V_O = V_{KA} = V_{REF} \times (1 + R_1/R_2) + I_{REF} \times R_1$

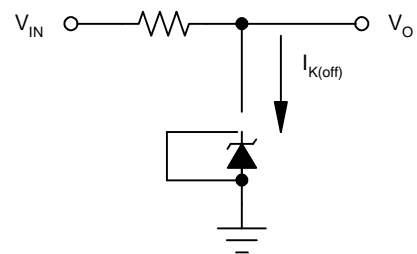
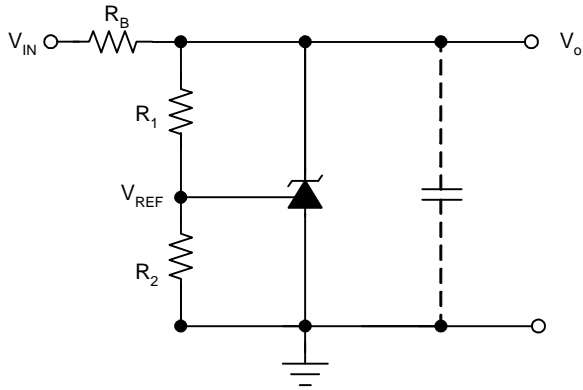
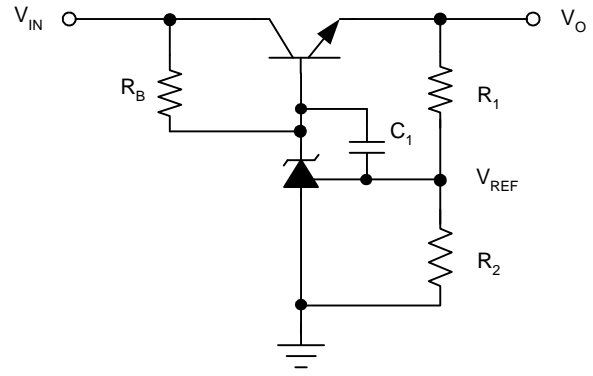

Figure 3. Test Circuit for  $I_{K(\text{off})}$

Typical Application Circuits



Precision Voltage Reference



Precision High-Current Series Regulator

Notes for Typical Application Circuits:

- 1) For the series regulator applications, add a compensation capacitor C1 between CATHODE and REF is strongly recommended to improve the stability of output voltage .
- 2) Set  $V_o$  according to the following equation:  $V_o = V_{REF} \cdot (1 + R1/R2) + I_{REF} \cdot R1$
- 3) Choose the value for  $R_B$  as below:
  - A) The maximum limit for  $R_B$  should be such that the cathode current ( $I_k$ ) is greater than the minimum operating current (0.5mA) at  $V_{IN(MIN)}$ .
  - B) The minimum limit for  $R_B$  should be such that the cathode current ( $I_k$ ) does not exceed 100mA under all load conditions, and the instantaneous turn-on value for  $I_k$  does not exceed 120mA.

Typical Operating Characteristics

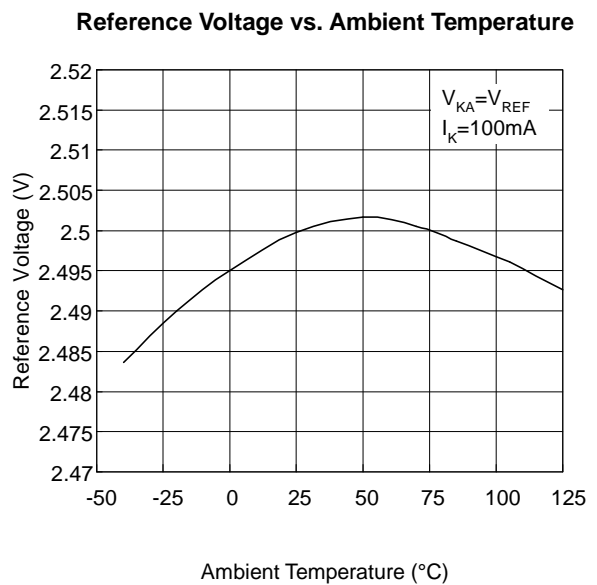
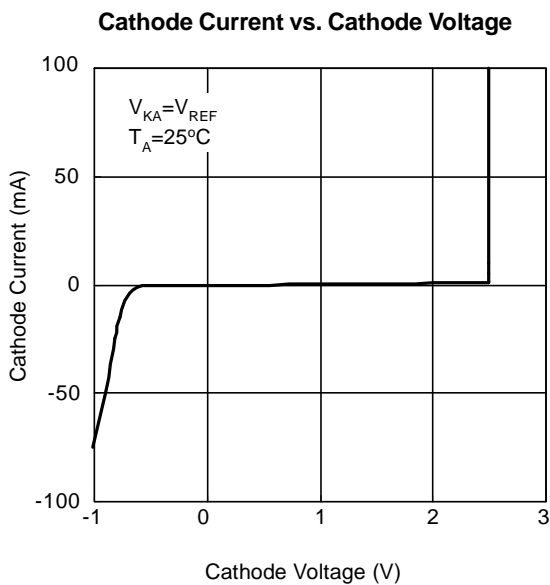
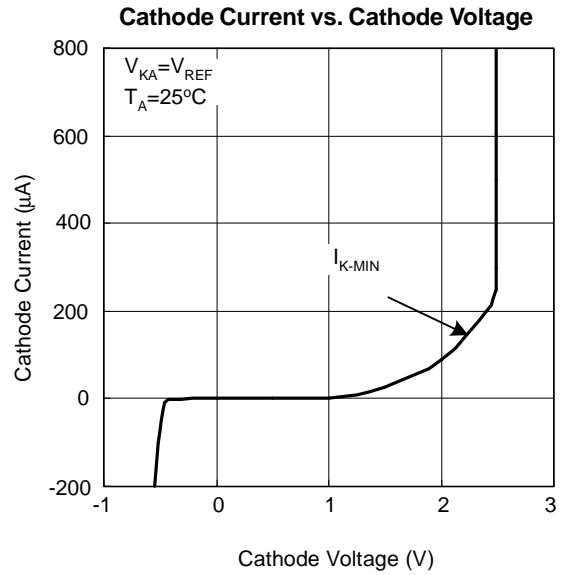
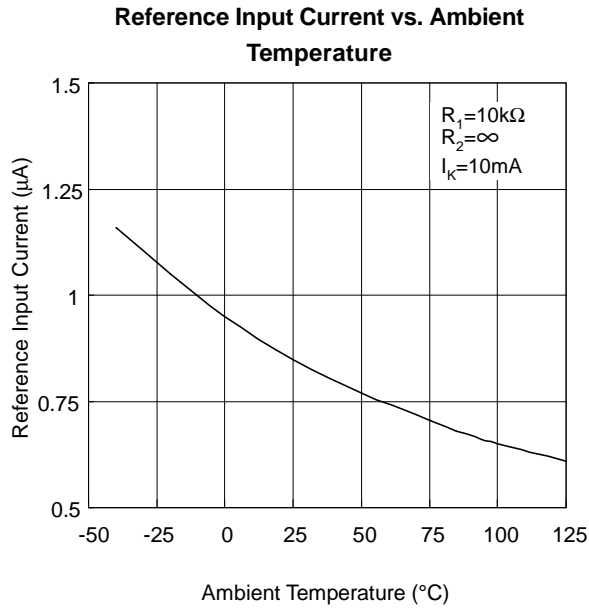

Typical Operating Characteristics (Cont.)

Off State Cathode Current vs. Cathode Voltage

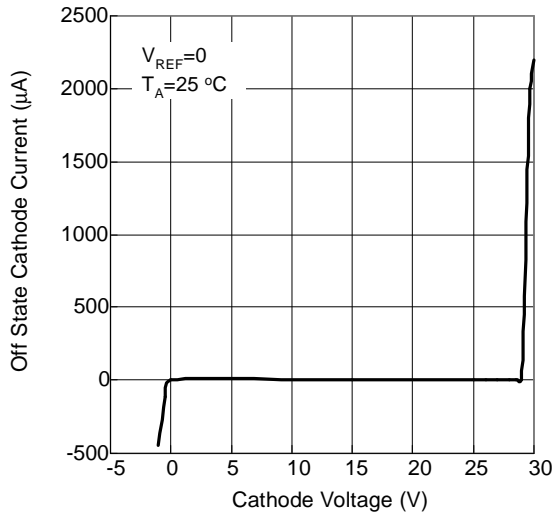

Pulse Response

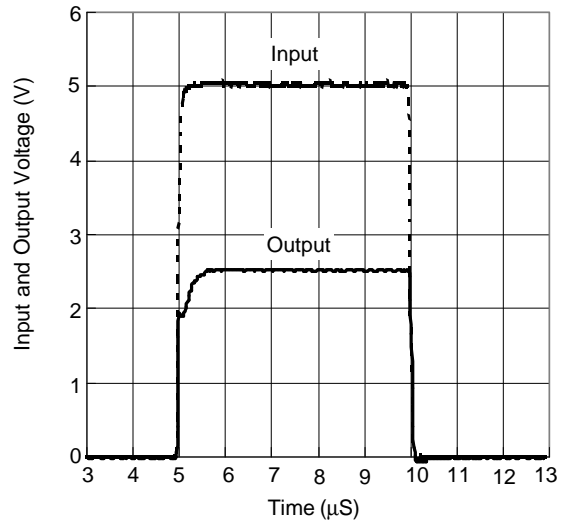

Off-State Cathode Current vs. Ambient Temperature

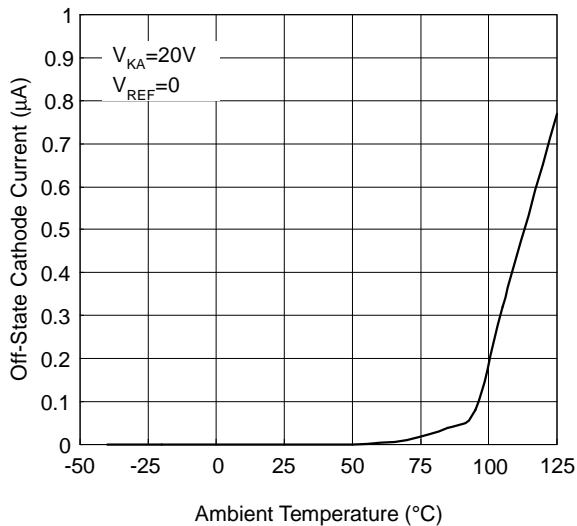

Ratio of Delta Reference Voltage to Delta Cathode Voltage vs. Ambient Temperature

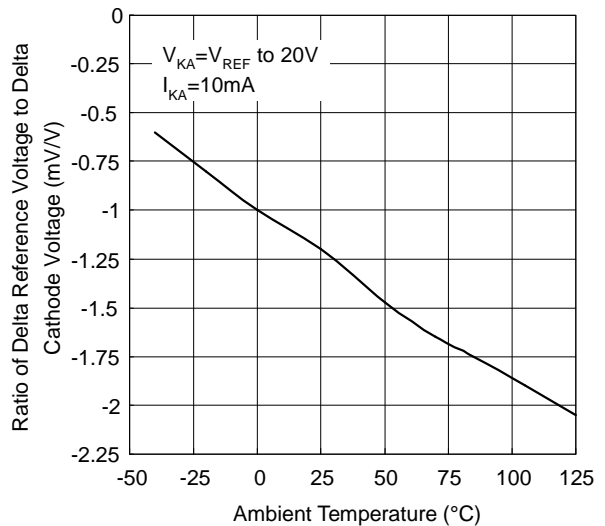

Typical Operating Characteristics (Cont.)

Small-Signal Voltage Amplification vs. Frequency

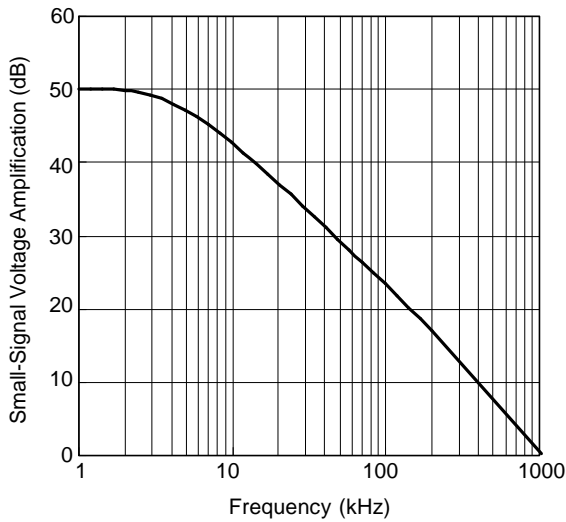

Stability Boundary Conditions

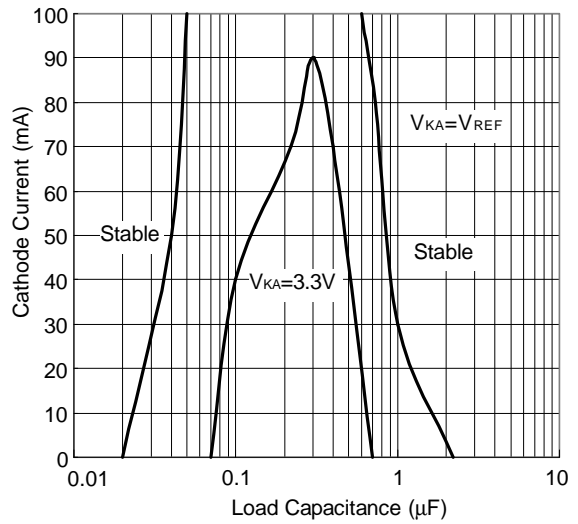

Reference Impedance vs. Frequency

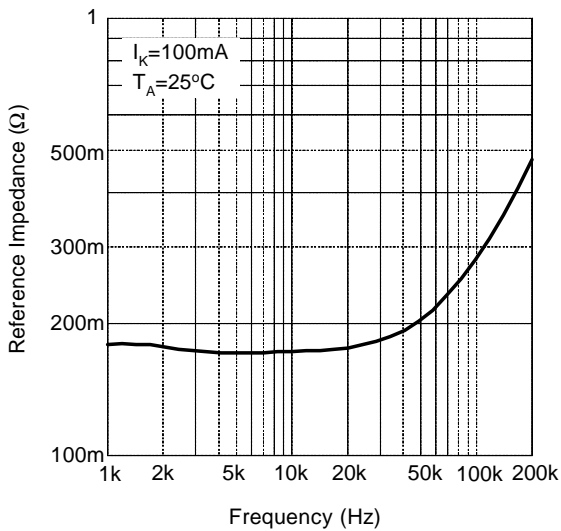

Power Dissipation vs. Ambient Temperature

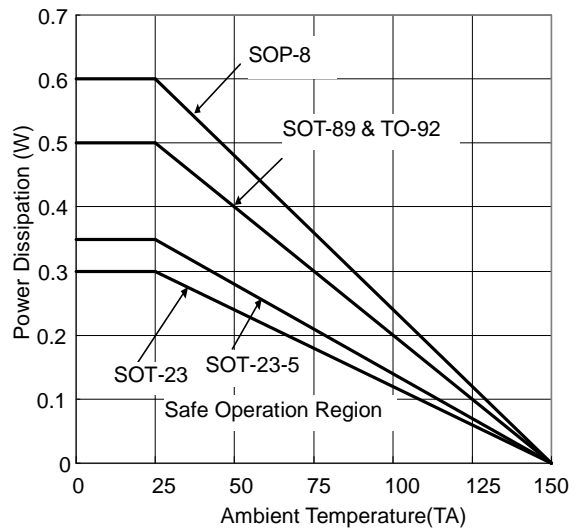

Typical Operating Characteristics (Cont.)

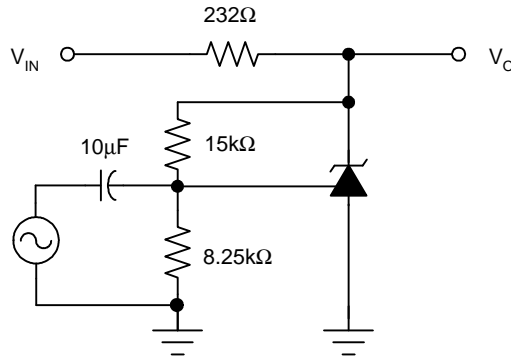

Voltage Amplification Test Circuit

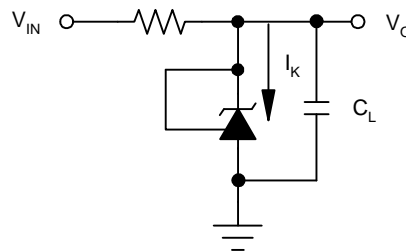

Stability Test Circuit for V<sub>KA</sub> = V<sub>REF</sub>

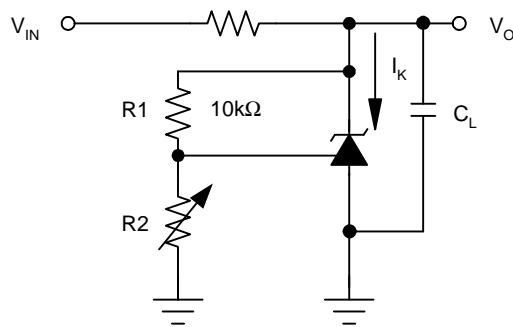

Stability Test Circuit for V<sub>KA</sub> > V<sub>REF</sub>  
 $V_O = V_{KA} = V_{REF} \times (1 + R1/R2) + I_{REF} \times R1$   
 Use the MLCC for C<sub>L</sub>



Package Information

SOT-23-3

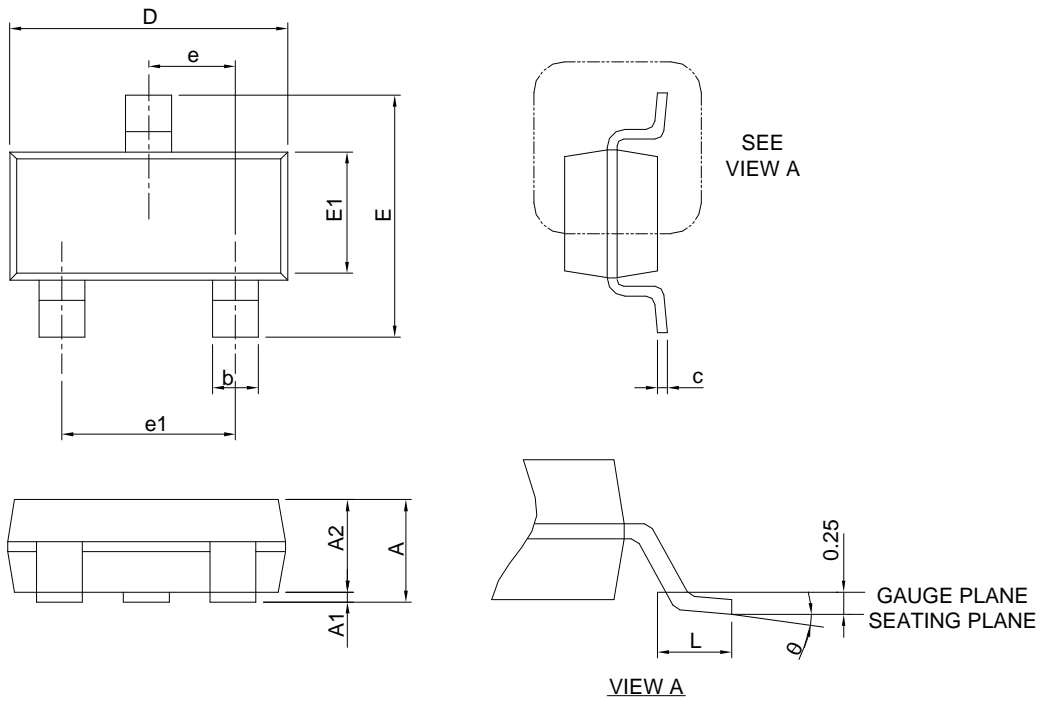

SYMBOL	SOT-23-3			
	MILLIMETERS		INCHES	
	MIN.	MAX.	MIN.	MAX.
A		1.45		0.057
A1	0.00	0.15	0.000	0.006
A2	0.90	1.30	0.035	0.051
b	0.30	0.50	0.012	0.020
c	0.08	0.22	0.003	0.009
D	2.70	3.10	0.106	0.122
E	2.60	3.00	0.102	0.118
E1	1.40	1.80	0.055	0.071
e	0.95 BSC		0.037 BSC	
e1	1.90 BSC		0.075 BSC	
L	0.30	0.60	0.012	0.024
$\theta$	0°	8°	0°	8°

Note : Dimension D and E1 do not include mold flash, protrusions or gate burrs. Mold flash, protrusion or gate burrs shall not exceed 10 mil per side.

Package Information

SOT-23-5

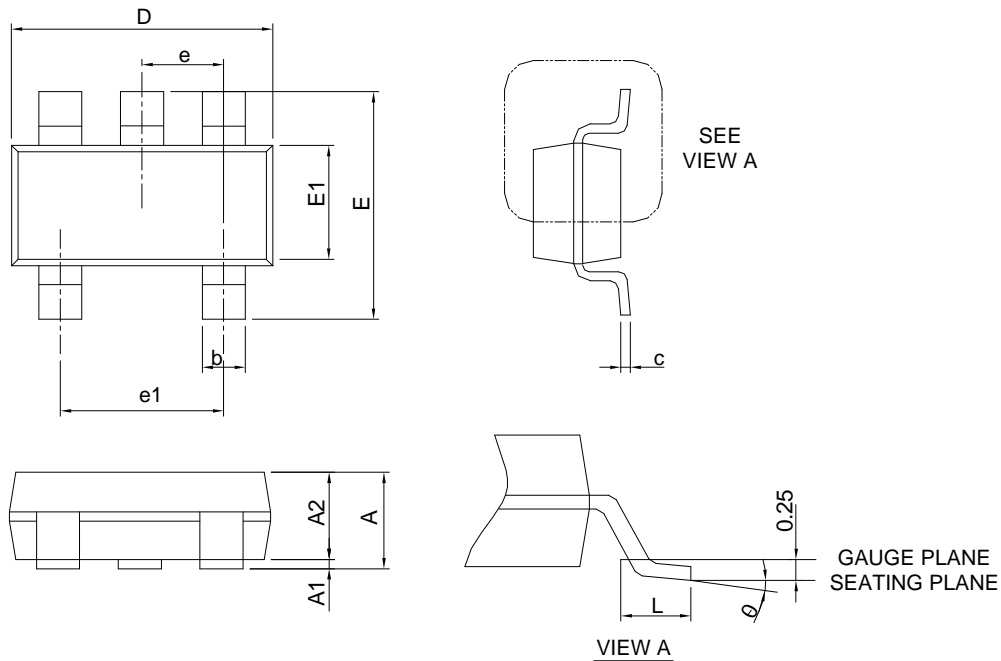

SYMBOL	SOT-23-5			
	MILLIMETERS		INCHES	
	MIN.	MAX.	MIN.	MAX.
A		1.45		0.057
A1	0.00	0.15	0.000	0.006
A2	0.90	1.30	0.035	0.051
b	0.30	0.50	0.012	0.020
c	0.08	0.22	0.003	0.009
D	2.70	3.10	0.106	0.122
E	2.60	3.00	0.102	0.118
E1	1.40	1.80	0.055	0.071
e	0.95 BSC		0.037 BSC	
e1	1.90 BSC		0.075 BSC	
L	0.30	0.60	0.012	0.024
θ	0°	8°	0°	8°

Note : 1. Follow JEDEC TO-178 AA.  
 2. Dimension D and E1 do not include mold flash, protrusions or gate burrs. Mold flash, protrusion or gate burrs shall not exceed 10 mil per side.

## Package Information

SOT-89

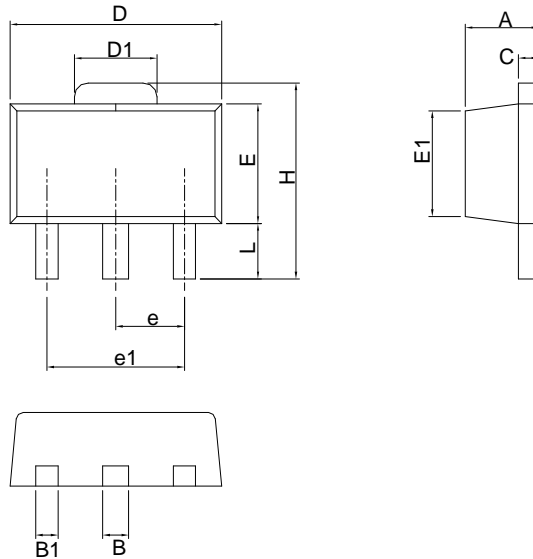

SYMBOL	SOT-89			
	MILLIMETERS		INCHES	
	MIN.	MAX.	MIN.	MAX.
A	1.40	1.60	0.055	0.063
B	0.44	0.56	0.017	0.022
B1	0.36	0.48	0.014	0.019
C	0.35	0.44	0.014	0.017
D	4.40	4.60	0.173	0.181
D1	1.62	1.83	0.064	0.072
E	2.29	2.60	0.090	0.102
E1	2.13	2.29	0.084	0.090
e	1.50 BSC		0.059 BSC	
e1	3.00 BSC		0.118 BSC	
H	3.94	4.25	0.155	0.167
L	0.89	1.20	0.035	0.047

Note : Follow JEDEC TO-243 AA.

Package Information

TO-92

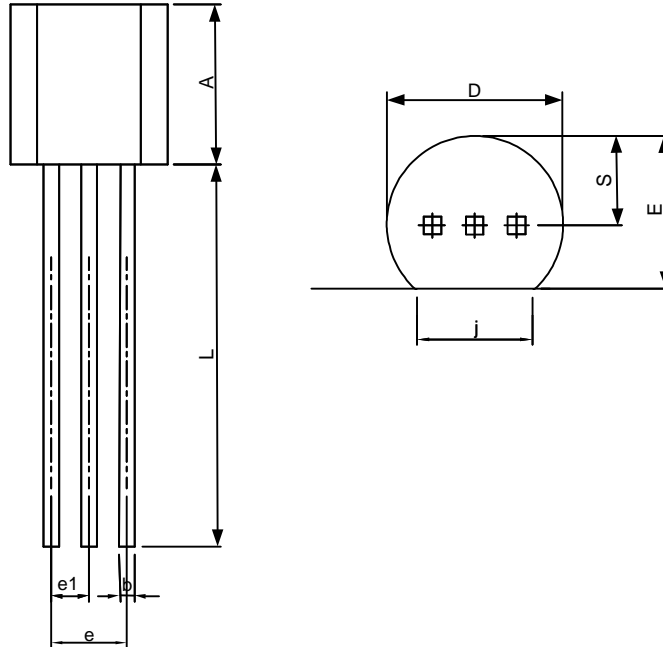

SYMBOL	TO-92			
	MILLIMETERS		INCHES	
	MIN.	MAX.	MIN.	MAX.
A	4.32	5.33	0.170	0.210
b	0.41	0.53	0.016	0.021
D	4.45	5.20	0.175	0.205
E	3.18	4.19	0.125	0.165
e	2.42	2.66	0.095	0.105
e1	1.15	1.39	0.045	0.055
j	3.43	4.00	0.135	0.157
L	12.70	15.00	0.500	0.591
S	2.03	2.66	0.080	0.105

Note : Follow JEDEC TO-92.

Package Information

SOP-8

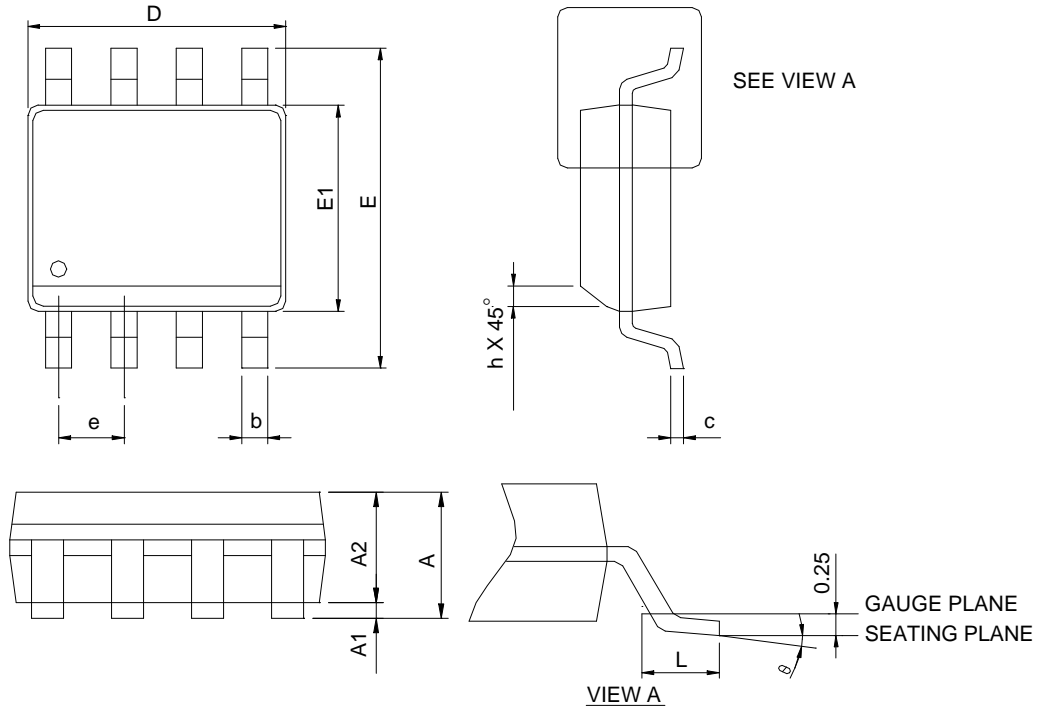

SYMBOL	SOP-8			
	MILLIMETERS		INCHES	
	MIN.	MAX.	MIN.	MAX.
A		1.75		0.069
A1	0.10	0.25	0.004	0.010
A2	1.25		0.049	
b	0.31	0.51	0.012	0.020
c	0.17	0.25	0.007	0.010
D	4.80	5.00	0.189	0.197
E	5.80	6.20	0.228	0.244
E1	3.80	4.00	0.150	0.157
e	1.27 BSC		0.050 BSC	
h	0.25	0.50	0.010	0.020
L	0.40	1.27	0.016	0.050
$\theta$	0°	8°	0°	8°

- Note: 1. Follow JEDEC MS-012 AA.  
 2. Dimension "D" does not include mold flash, protrusions or gate burrs. Mold flash, protrusion or gate burrs shall not exceed 6 mil per side.  
 3. Dimension "E" does not include inter-lead flash or protrusions. Inter-lead flash and protrusions shall not exceed 10 mil per side.

Carrier Tape & Reel Dimensions

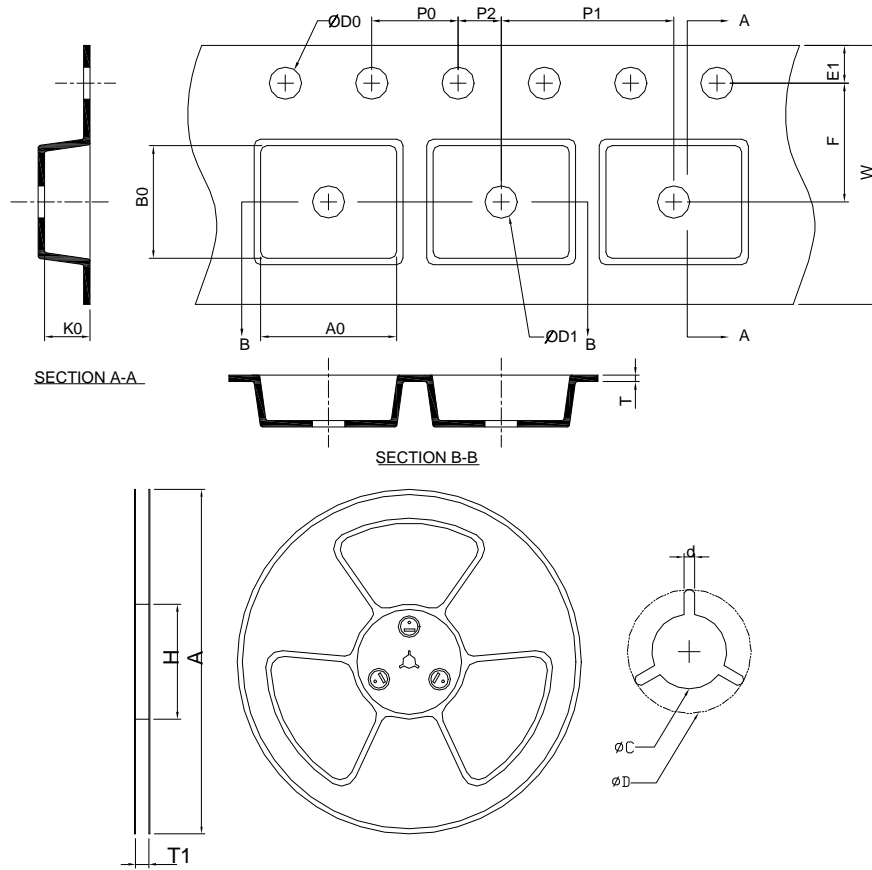

Application	A	H	T1	C	d	D	W	E1	F
SOT-23-3	178.0 ±0.00	50 MIN.	8.4+2.00 -0.00	13.0+0.50 -0.20	1.5 MIN.	20.2 MIN.	8.0 ±0.30	1.75 ±0.10	3.5 ±0.05
	<b>P0</b>	<b>P1</b>	<b>P2</b>	<b>D0</b>	<b>D1</b>	<b>T</b>	<b>A0</b>	<b>B0</b>	<b>K0</b>
	4.0 ±0.10	4.0 ±0.10	2.0 ±0.05	1.5+0.10 -0.00	1.0 MIN.	0.6+0.00 -0.40	3.20 ±0.20	3.10 ±0.20	1.50 ±0.20
Application	A	H	T1	C	d	D	W	E1	F
SOT-23-5	178.0 ±0.00	50 MIN.	8.4+2.00 -0.00	13.0+0.50 -0.20	1.5 MIN.	20.2 MIN.	8.0 ±0.30	1.75 ±0.10	3.5 ±0.05
	<b>P0</b>	<b>P1</b>	<b>P2</b>	<b>D0</b>	<b>D1</b>	<b>T</b>	<b>A0</b>	<b>B0</b>	<b>K0</b>
	4.0 ±0.10	4.0 ±0.10	2.0 ±0.05	1.5+0.10 -0.00	1.0 MIN.	0.6+0.00 -0.40	3.20 ±0.20	3.10 ±0.20	1.50 ±0.20
Application	A	H	T1	C	d	D	W	E1	F
SOT-89	178.0 ±0.00	50 MIN.	12.4+2.00 -0.00	13.0+0.50 -0.20	1.5 MIN.	20.2 MIN.	12.0 ±0.30	1.75 ±0.10	5.50 ±0.05
	<b>P0</b>	<b>P1</b>	<b>P2</b>	<b>D0</b>	<b>D1</b>	<b>T</b>	<b>A0</b>	<b>B0</b>	<b>K0</b>
	4.0 ±0.10	8.0 ±0.10	2.0 ±0.05	1.5+0.10 -0.00	1.5 MIN.	0.6+0.00 -0.40	4.80 ±0.20	4.50 ±0.20	1.80 ±0.20

(mm)

**Carrier Tape & Reel Dimensions (Cont.)**

Application	A	H	T1	C	d	D	W	E1	F
SOP-8	330.0 ±0.00	50 MIN.	12.4+2.00 -0.00	13.0+0.50 -0.20	1.5 MIN.	20.2 MIN.	12.0 ±0.30	1.75 ±0.10	5.5 ±0.05
	P0	P1	P2	D0	D1	T	A0	B0	K0
	4.0 ±0.10	8.0 ±0.10	2.0 ±0.05	1.5+0.10 -0.00	1.5 MIN.	0.6+0.00 -0.40	6.40 ±0.20	5.20 ±0.20	2.10 ±0.20

(mm)

**Carrier Tape & Box Dimensions**

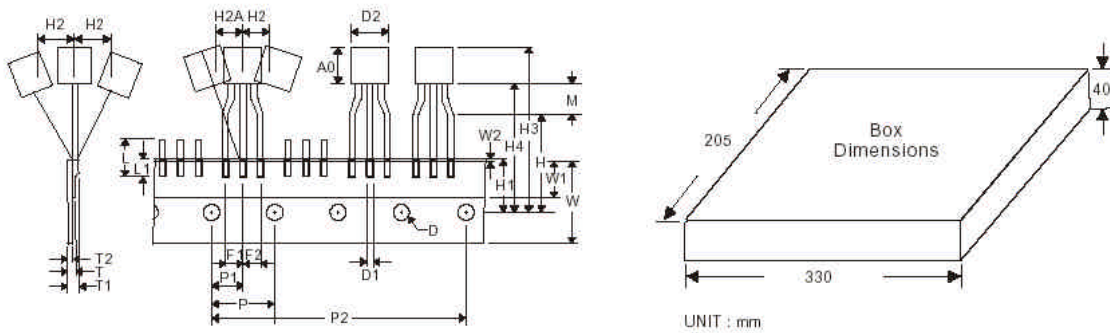

**Devices Per Unit**

Package Type	Unit	Quantity
SOT-23-3	Tape & Reel	3000
SOT-23-5	Tape & Reel	3000
SOT-89	Tape & Reel	1000
TO-92	Tape & Box	2000
SOP-8	Tape & Reel	2500

### Taping Direction Information

SOT-23-3

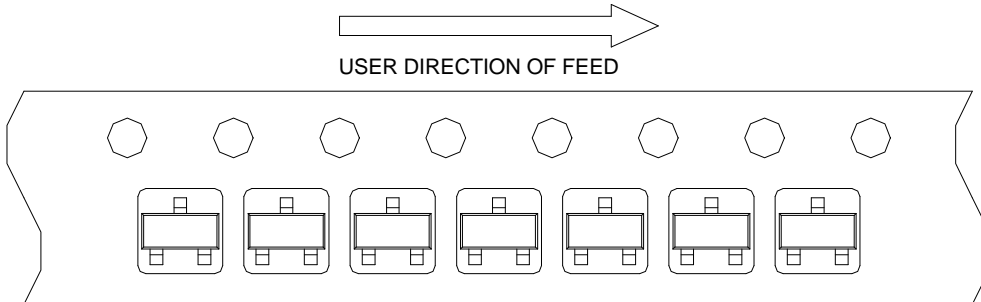

SOT-23-5

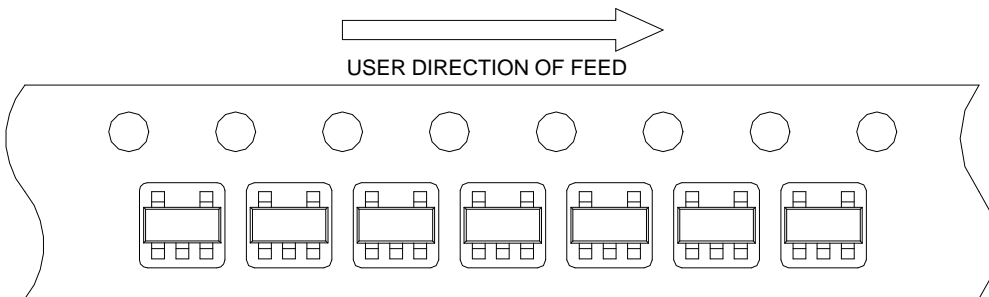

SOT-89

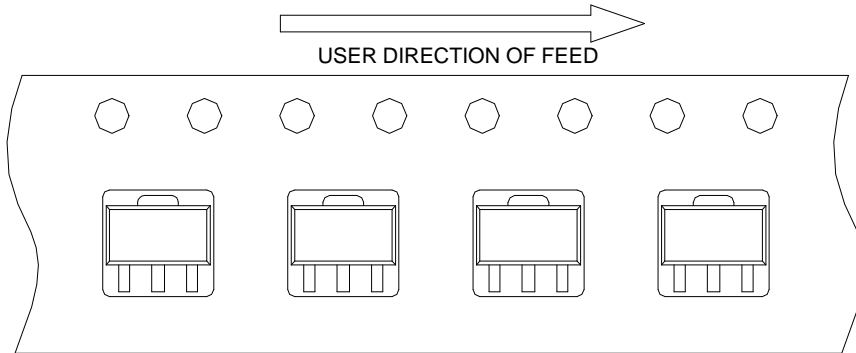

SOP-8

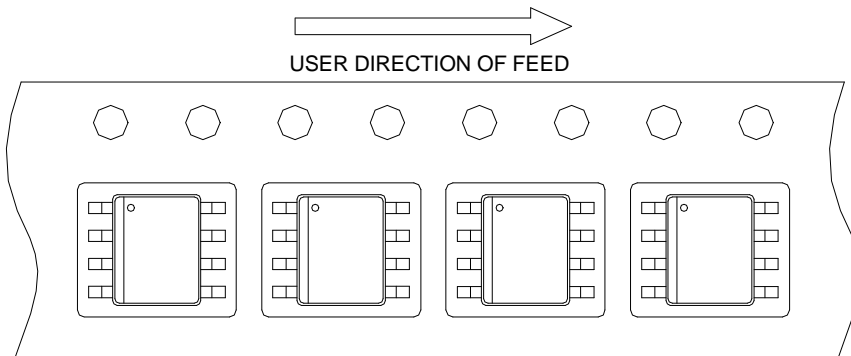



Classification Profile

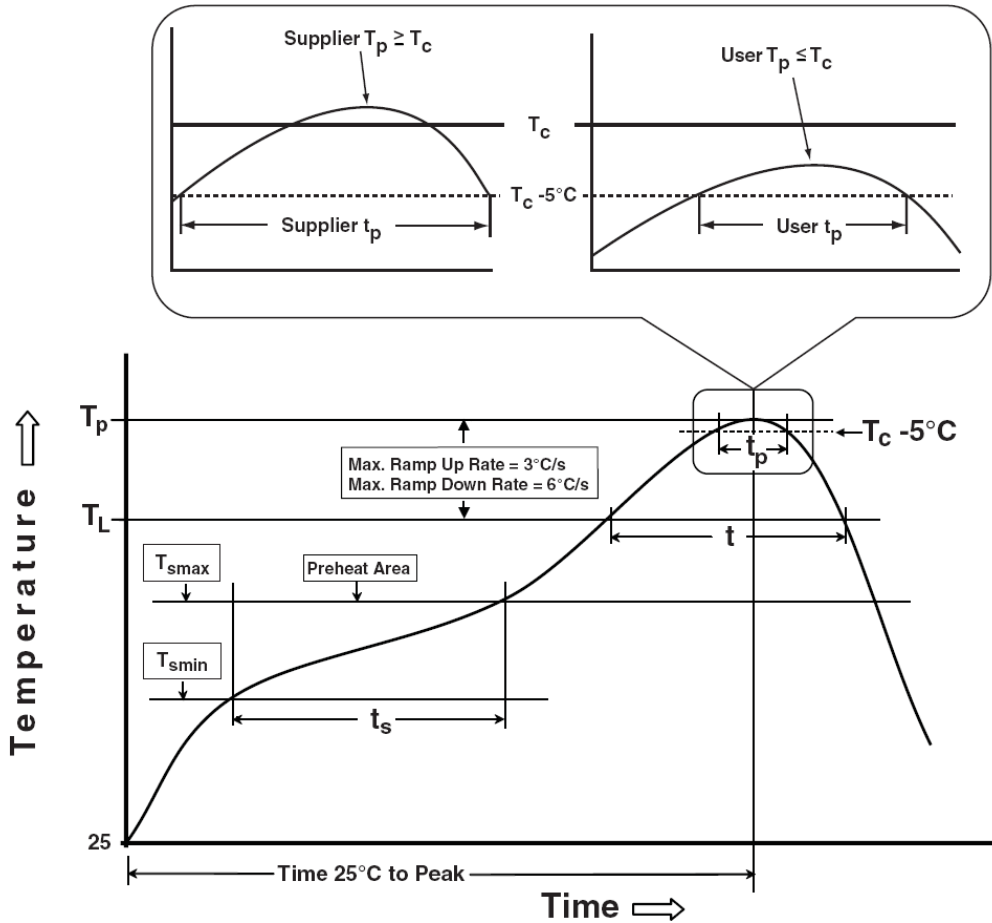

Classification Reflow Profiles

Profile Feature	Sn-Pb Eutectic Assembly	Pb-Free Assembly
<b>Preheat &amp; Soak</b>		
Temperature min ( $T_{smin}$ )	100 °C	150 °C
Temperature max ( $T_{smax}$ )	150 °C	200 °C
Time ( $T_{smin}$ to $T_{smax}$ ) ( $t_s$ )	60-120 seconds	60-120 seconds
Average ramp-up rate ( $T_{smax}$ to $T_p$ )	3 °C/second max.	3°C/second max.
Liquidous temperature ( $T_L$ )	183 °C	217 °C
Time at liquidous ( $t_l$ )	60-150 seconds	60-150 seconds
Peak package body Temperature ( $T_p$ )*	See Classification Temp in table 1	See Classification Temp in table 2
Time ( $t_p$ )** within 5°C of the specified classification temperature ( $T_c$ )	20** seconds	30** seconds
Average ramp-down rate ( $T_p$ to $T_{smax}$ )	6 °C/second max.	6 °C/second max.
Time 25°C to peak temperature	6 minutes max.	8 minutes max.

\* Tolerance for peak profile Temperature ( $T_p$ ) is defined as a supplier minimum and a user maximum.

\*\* Tolerance for time at peak profile temperature ( $t_p$ ) is defined as a supplier minimum and a user maximum.

**Classification Reflow Profiles (Cont.)**

Table 1. SnPb Eutectic Process – Classification Temperatures (Tc)

Package Thickness	Volume mm <sup>3</sup> <350	Volume mm <sup>3</sup> ≥350
<2.5 mm	235 °C	220 °C
≥2.5 mm	220 °C	220 °C

Table 2. Pb-free Process – Classification Temperatures (Tc)

Package Thickness	Volume mm <sup>3</sup> <350	Volume mm <sup>3</sup> 350-2000	Volume mm <sup>3</sup> >2000
<1.6 mm	260 °C	260 °C	260 °C
1.6 mm – 2.5 mm	260 °C	250 °C	245 °C
≥2.5 mm	250 °C	245 °C	245 °C

**Reliability Test Program**

Test item	Method	Description
SOLDERABILITY	JESD-22, B102	5 Sec, 245°C
HOLT	JESD-22, A108	1000 Hrs, Bias @ 125°C
PCT	JESD-22, A102	168 Hrs, 100%RH, 2atm, 121°C
TCT	JESD-22, A104	500 Cycles, -65°C~150°C
ESD	MIL-STD-883-3015.7	VHBM 2KV, VMM 200V
Latch-Up	JESD 78	10ms, 1 <sub>tr</sub> 100mA

**Customer Service**

**Anpec Electronics Corp.**

Head Office :

No.6, Dusing 1st Road, SBIP,

Hsin-Chu, Taiwan, R.O.C.

Tel : 886-3-5642000

Fax : 886-3-5642050

Taipei Branch :

2F, No. 11, Lane 218, Sec 2 Jhongsing Rd.,

Sindian City, Taipei County 23146, Taiwan

Tel : 886-2-2910-3838

Fax : 886-2-2917-3838