

## Single-Phase Full-Wave Motor Driver for Fan Motor

### Features

- **Single Phase Full Wave Fan Driver**
- **Low Quiescent Current**
- **Built-in Variable Speed Function**
- **OTP Setting ShutDown Mode or Minimum speed mode**
- **OTP Setting Minimum Input and Output Duty**
- **OTP Setting Maximum Input Duty for Full Duty Output or Setting Maximum Output Duty for 100% PWM Input**
- **OTP Setting Enable Soft Start Function**
- **Current Limit Circuit**
- **Built-in Lock Protection and Auto Restart Function**
- **FG Output (SEL floating) or RD Output (SEL GND)**
- **Built-in Thermal Protection Circuit**
- **Lead Free and Green Device Available (RoHS Compliant)**

### General Description

The APX9766A is a single phase full wave DC brushless motor driver with PWM variable speed control and current limit features suitable for the fan of personal computer's power supply and CPU cooler. The PWM control system fixed input and output duty through internal OTP block setting. The device is equipped with a built-in lock protection, which protects the fan when it is locked. It also has rotation speed detection output and thermal protection function. The APX9766A is available in SOP-10 and TSSOP-14 package (see Pin Configuration).

### Applications

- **CPU Cooler Fans**
- **Variable Speed Control Fans**

### Ordering and Marking Information

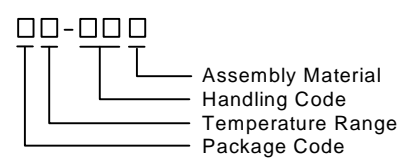
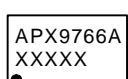
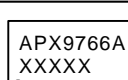
<p>APX9766A</p> 	<p>Package Code                  K: SOP-10 O: TSSOP-14                  Operating Ambient Temperature Range                  I: -40 to 90 °C                  Handling Code                  TR : Tape &amp; Reel                  Assembly Material                  G: Halogen and Lead Free Device</p>
<p>APX9766A K :</p> 	<p>XXXXX - Date Code</p>
<p>APX9766A O :</p> 	<p>XXXXX - Date Code</p>

Note: ANPEC lead-free products contain molding compounds/die attach materials and 100% matte tin plate termination finish; which are fully compliant with RoHS. ANPEC lead-free products meet or exceed the lead-free requirements of IPC/JEDEC J-STD-020D for MSL classification at lead-free peak reflow temperature. ANPEC defines "Green" to mean lead-free (RoHS compliant) and halogen free (Br or Cl does not exceed 900ppm by weight in homogeneous material and total of Br and Cl does not exceed 1500ppm by weight).

ANPEC reserves the right to make changes to improve reliability or manufacturability without notice, and advise customers to obtain the latest version of relevant information to verify before placing orders.

## Pin Configuration

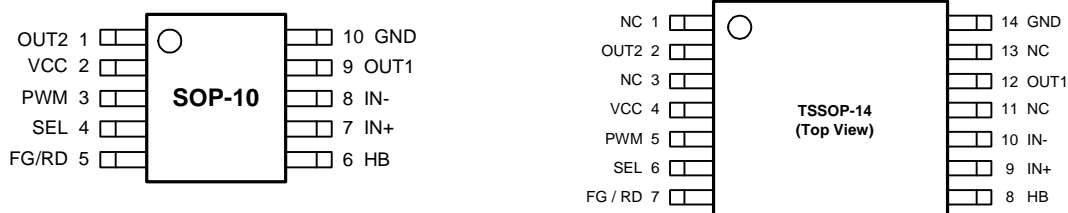

## Absolute Maximum Ratings (Note 1)

Symbol	Parameter	Ratings	Unit
$V_{CC}$	VCC Pin Supply Voltage (VCC to GND)	-0.3 to 18	V
$I_{OUT}$	OUT1, OUT2 Pin Maximum Output Current	1	A
$V_{OUT1, OUT2}$	OUT1, OUT2 Pin Output Voltage	VGND-0.3 to VCC	V
$V_{PWM}$	PWM Pin Input Voltage (PWM to GND)	-0.3 to 18	V
	FG Pin Output Voltage	-0.3 to 18	V
$I_{FG}$	FG Pin Maximum Output Sink Current	10	mA
$I_{HB}$	HB Pin Output Source Current	10	mA
$T_J$	Maximum Junction Temperature	150	°C
$T_{STG}$	Storage Temperature	-65 to 150	°C
$T_{SDR}$	Maximum Lead Soldering Temperature, 10 Seconds	260	°C

Note1: Stresses beyond those listed under "absolute maximum ratings" may cause permanent damage to the device. These are stress ratings only and functional operation of the device at these or any other conditions beyond those indicated under "recommended operating conditions" is not implied. Exposure to absolute maximum rating conditions for extended periods may affect device reliability

## Thermal Characteristics

Symbol	Parameter	Typical Value	Unit
$R_{TH,JA}$	Thermal Resistance-Junction to Ambient <small>(Note 2)</small>	TSSOP-14	125
		SOP-10	147
$P_D$	Power Dissipation, $T_A=25^{\circ}C$	TSSOP-14	1
		SOP-10	0.85

Note 2:  $R_{TH,JA}$  is measured with the component mounted on a high effective thermal conductivity test board in free air.

## Recommended Operation Conditions (Note 3)

Symbol	Parameter	Range	Unit
$V_{CC}$	VCC Pin Supply Voltage Range	3.5 to 15	V
$V_{ICM}$	Hall Input (IN+, IN-) Common-Phase Input Voltage Range	0.2 to 3	V
$T_A$	Ambient Temperature	-40 to 90	°C
$T_J$	Junction Temperature	-40 to 125	°C

Note 3: Refer to the typical application circuit.

## Electrical Characteristics ( $V_{CC}=12V$ , $T_A=25^\circ C$ . unless otherwise specified)

Symbol	Parameter	Test Conditions	APX9766A			Unit
			Min	Typ	Max	
<b>SUPPLY CURRENT</b>						
$V_{HB}$	HB Pin Output Voltage	$I_{HB} = 5mA$	1.06	1.1	1.14	V
$I_{CC1}$	Operating Current	Rotation Mode	-	5	8	mA
$I_{CC2}$		Lock Protection Mode	-	5	8	
$I_{CC3}$		PWM=0% (OUTPUT=0%)	-	1.5	2	
<b>LOCK PROTECTION</b>						
$T_{ON}$	Lock Detection On Time	User define by OTP programming	0.5	-	1	sec
$T_{OFF}$	Lock Detection Off Time	User define by OTP programming	3.5	-	10	sec
$R_{LOCK}$	$T_{OFF}/T_{ON}$ Ratio	$R_{LOCK} = T_{OFF}/T_{ON}$	-	7 or 10	-	-
<b>SOFT START</b>						
$T_{SS}$	Soft Start Time	User enable by OTP programming	-	$13 \cdot T_{ON}$	-	sec
<b>OUTPUT DRIVERS</b>						
$V_O$	Output Driver Saturation Voltage	$I_{OUT} = 200mA$ , Upper and Lower total	-	0.25	0.5	V
$V_{FG}$	FG Pin Low Voltage	$I_{FG} = 5mA$	-	0.1	0.2	V
$I_{FGL}$	FG Pin Leakage Current	$V_{FG} = 12V$	-	<0.1	1	$\mu A$
<b>PWM CONTROL</b>						
$V_{PWH}$	PWM Pin Input High Level Voltage		2	-	$V_{CC}+0.3$	V
$V_{PWL}$	PWM Pin Input Low Level Voltage		-0.3	-	0.8	V
$R_{PWM\_PU}$	PWM Internal pull-up Resistor	$V_{PWM} = 5V$	-	20	-	K $\Omega$
$V_{PWM\_PU}$	PWM Internal pull-up Voltage	$V_{PWM} = 0V$	-	4.8	-	V
$F_{PWM}$	PWM Pin Input Frequency		20	-	50	KHz
<b>INPUT-OUTPUT DUTY</b>						
$D_{MIN}$	Minimum Input Duty for $DO_{MIN}$ setting	User define by OTP programming	0	-	100	%
$D_{HYS}$	Input Duty hysteresis of $D_{MIN}$	For Shutdown Mode	0.5	-	-	%
$DO_{MIN}$	Minimum Output Duty for $D_{MIN}$ setting	User define by OTP programming	0	-	100	%
$D_{MAX}$	Maximum Input Duty for Full Duty Output	User define by OTP programming	60	-	100	%
$DO_{MAX}$	Maximum Output Duty for 100% PWM Input	User define by OTP programming	60	-	100	%
$R_{OI}$	Ratio of $DO_{MIN}$ and $D_{MIN}$ setting	$(DO_{MAX}-DO_{MIN})/(D_{MAX}-D_{MIN})$	0	-	2	
<b>HALL SENSITIVITY</b>						
$V_{HN}$	Hall Input Sensitivity	Zero to peak including offset and hysteresis	-	10	20	mV
<b>CURRENT LIMIT</b>						
$I_{LM}$	Internal Current Limit		-	1000	-	mA
<b>THERMAL PROTECTION</b>						
$T_{OTS}$	Over Temperature Shutdown Threshold		-	165	-	$^\circ C$
	Over Temperature Shutdown Hysteresis		-	30	-	

## Pin Description

### SOP-10

PIN		FUNCTION
NO.	NAME	
1	OUT2	H-bridge Output Connection.
2	VCC	Supply Voltage Input Pin.
3	PWM	PWM Signal Input Terminal.
4	SEL	FG/RD Function Select Pin.
5	FG/RD	Rotation Speed or Detection Output. This is an open-drain output.
6	HB	Hall Bias. This is a 1.1V constant-voltage output for hall element bias.
7	IN+	Hall Input +. Connect to hall element positive output.
8	IN-	Hall Input -. Connect to hall element negative output.
9	OUT1	H-bridge Output Connection.
10	GND	Power GND.

### TSSOP-14

PIN		Function
NO.	NAME	
1	NC	No Connection.
2	OUT2	H-bridge Output Connection.
3	NC	No Connection.
4	VCC	Supply Voltage Input Pin.
5	PWM	PWM Signal Input Terminal.
6	SEL	FG / RD Function Select Pin.
7	FG / RD	Rotation Speed. This is an open-drain output.
8	HB	Hall Bias. This is a 1.1V constant-voltage output for hall element bias.
9	IN+	Hall Input +. Connect to hall element positive output.
10	IN-	Hall Input -. Connect to hall element negative output.
11	NC	No Connection.
12	OUT1	H-bridge Output Connection.
13	NC	No Connection.
14	GND	Power GND.

## Block Diagram

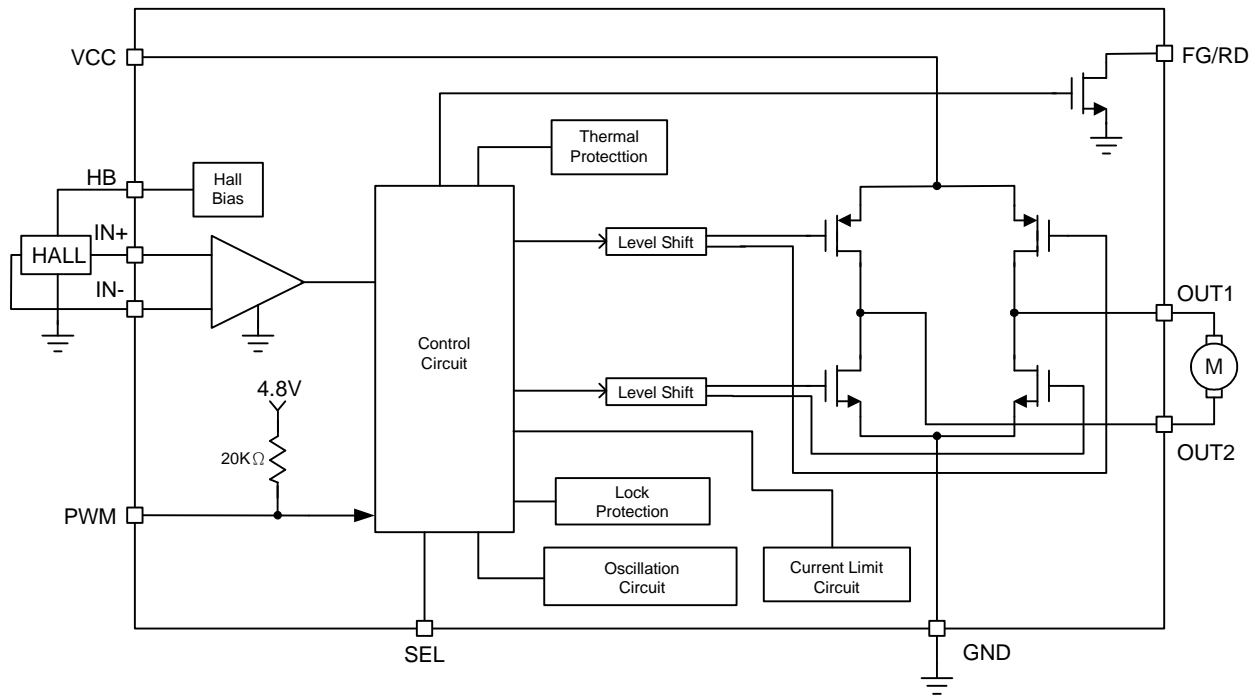

Typical Application Circuit

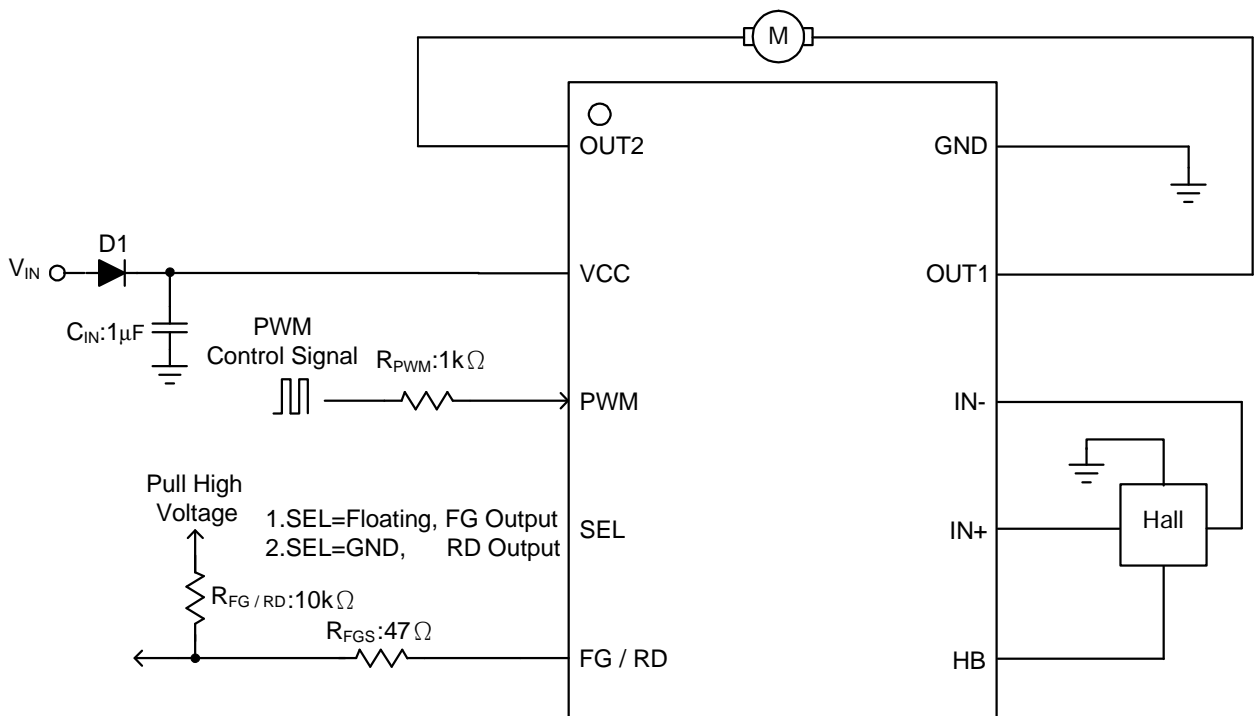

Note:  $R_{PWM}$  and  $R_{FGS}$  are optional to protect internal circuit for high voltage stress.

Note1:  $R_{FG/RD}$  must more than  $1k\Omega$  .

## Function Description

### External PWM Speed Control

The APX9766A embedded OTP (One Time Programming) block to set two mode, Shutdown and Min mode. The Shutdown mode can set two types input and output duties. (See Figure1: Shutdown mode Output Duty Control Curve) and the Min mode also can set two types input and output duties. (See Figure2: Minimum mode Output Duty Control Curve).

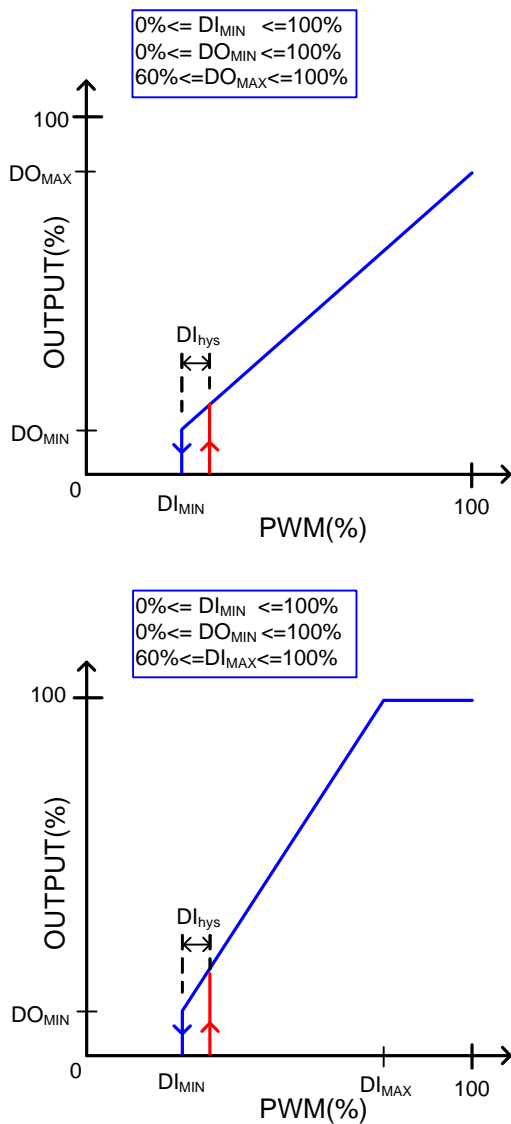

Figure1: Shutdown mode Output Duty Control Curve

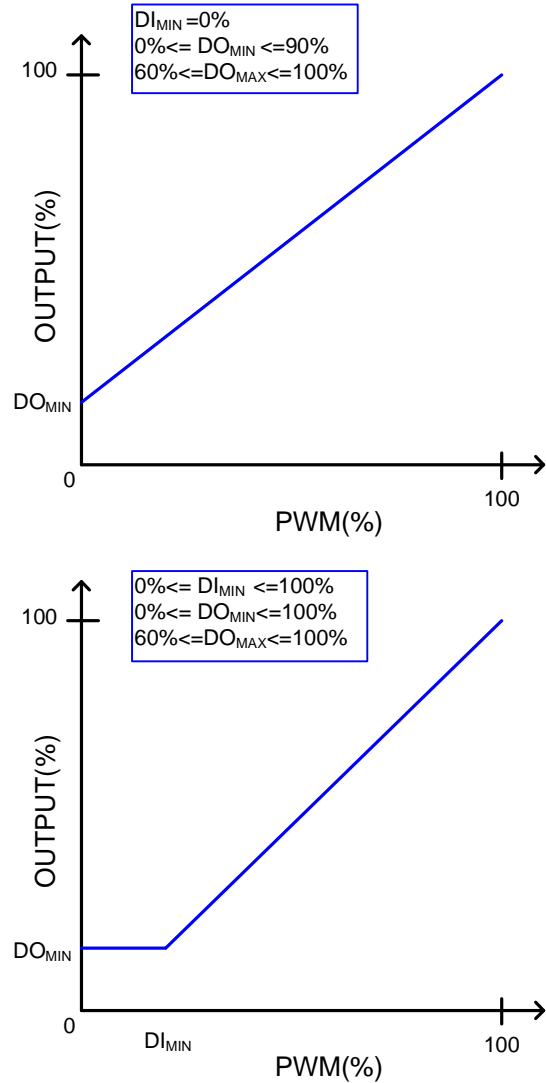

Figure2: Minimum mode Output Duty Control Curve

## Lockup Protection and Automatic Restart

This IC detects the rotation of the motor by the hall signal, and adjusts lock detection ON time ( $T_{ON}$ ) and lock detection OFF time ( $T_{OFF}$ ) by the internal counter. These times ( $T_{ON}$ ,  $T_{OFF}$ ) are shown below (see Figure 3: Lock/Auto Restart Waveform).

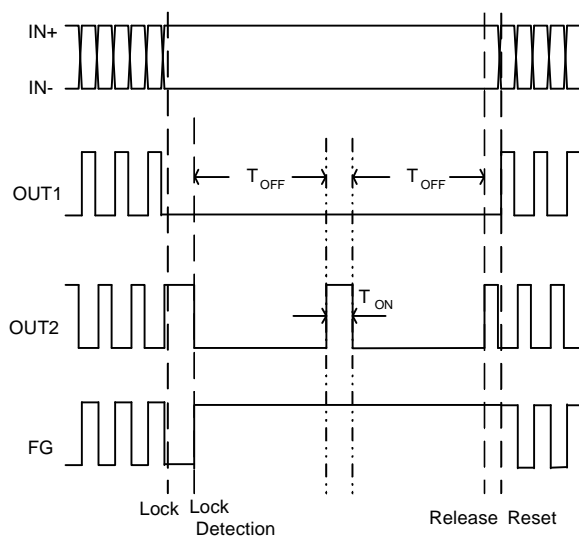

Figure3: Lock/Auto Restart Waveform

## FG Output

The FG pin is an open drain output connecting a pull up resistor to a high level voltage for the speed detection function. When  $V_{IN-}$  is larger than  $V_{IN+}$ , the  $V_{FG}$  is high (switch off); when  $V_{IN-}$  is smaller than  $V_{IN+}$ , the  $V_{FG}$  is low (switch on). Leave it open when not in using.

## Thermal Protection

The APX9766A is designed with a thermal protection to protect the IC from the damage of over temperature. When internal junction temperature reaches 165°C, the output devices will be switched off. When the IC's junction temperature cools by 30°C, the thermal sensor will turn the output devices on again resulting in a pulsed output during continuous thermal overload.

## Truth Table

Input		Output				Mode
IN-	IN+	OUT1	OUT2	FG	RD	
H	L	H	L	OFF	L	Rotation (Drive)
L	H	L	H	L	L	
H	L	OFF	L	OFF	L	Rotation (Regeneration)
L	H	L	OFF	L	L	
H	L	OFF	L	OFF	OFF	Lock Mode
L	H	L	OFF	OFF	OFF	

## Package Information

### TSSOP-14

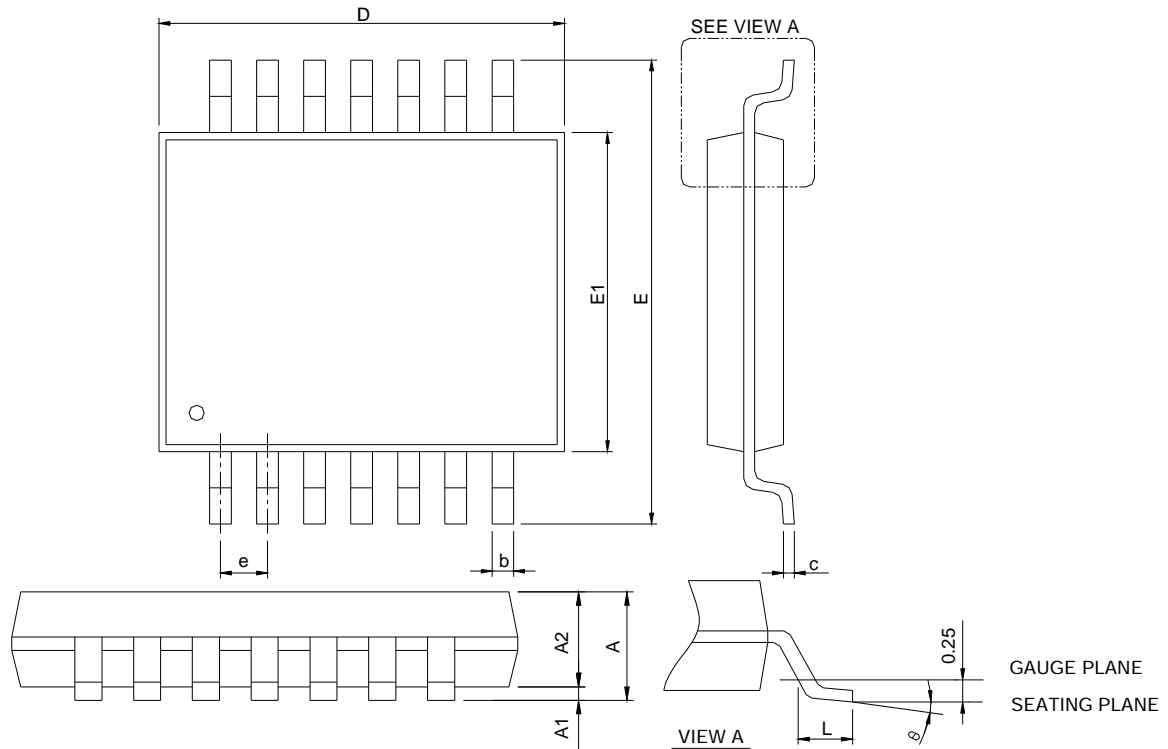

SYMBOL	TSSOP-14			
	MILLIMETERS		INCHES	
	MIN.	MAX.	MIN.	MAX.
A		1.20		0.047
A1	0.05	0.15	0.002	0.006
A2	0.80	1.05	0.031	0.041
b	0.19	0.30	0.007	0.012
c	0.09	0.20	0.004	0.008
D	4.90	5.10	0.193	0.201
E	6.20	6.60	0.244	0.260
E1	4.30	4.50	0.169	0.177
e	0.65 BSC		0.026 BSC	
L	0.45	0.75	0.018	0.030
θ	0°	8°	0°	8°

- Note : 1. Follow from JEDEC MO-153 AB-1.  
 2. Dimension "D" does not include mold flash, protrusions or gate burrs. Mold flash, protrusion or gate burrs shall not exceed 6 mil per side.  
 3. Dimension "E1" does not include inter-lead flash or protrusions. Inter-lead flash and protrusions shall not exceed 10 mil per side.

Package Information

SOP-10

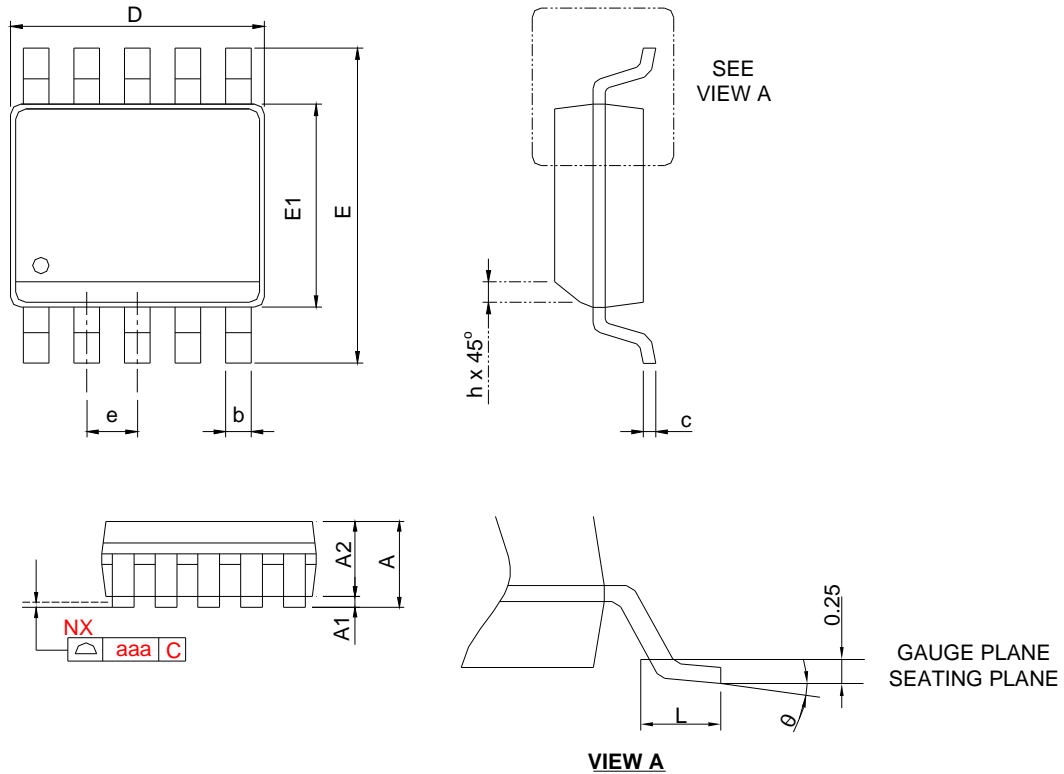

SYMBOL	SOP-10			
	MILLIMETERS		INCHES	
	MIN.	MAX.	MIN.	MAX.
A		1.75		0.069
A1	0.10	0.25	0.004	0.010
A2	1.25		0.049	
b	0.30	0.45	0.012	0.018
c	0.17	0.25	0.007	0.010
D	4.80	5.00	0.189	0.197
E	5.80	6.20	0.228	0.244
E1	3.80	4.00	0.150	0.157
e	1.00 BSC		0.039 BSC	
h	0.25	0.50	0.010	0.020
L	0.40	1.27	0.016	0.050
θ	0°	8°	0°	8°
aaa	0.10		0.004	

- Note:1. Dimension “D” does not include mold flash, protrusions or gate burrs.  
Mold flash, protrusion or gate burrs shall not flash or protrusions.  
2. Dimension “E” does not include inter-lead flash or protrusions.  
Inter-lead flash and protrusions shall not exceed 10 mil per side.

### Carrier Tape & Reel Dimensions

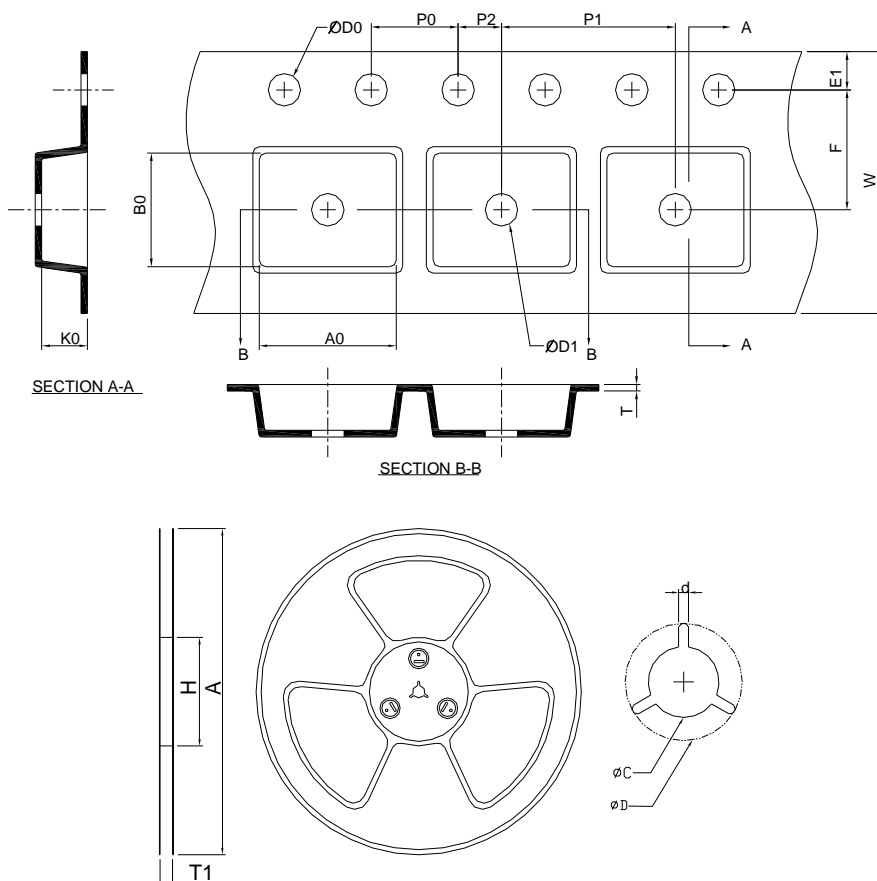

Application	A	H	T1	C	d	D	W	E1	F
TSSOP-14	330.0±2.00	50 MIN.	12.4+2.00 -0.00	13.0+0.50 -0.20	1.5 MIN.	20.2 MIN.	12.0±0.30	1.75±0.10	5.5±0.05
	P0	P1	P2	D0	D1	T	A0	B0	K0
	4.0±0.10	8.0±0.10	2.0±0.05	1.5+0.10 -0.00	1.5 MIN.	0.6+0.00 -0.40	6.80±0.20	5.40±0.20	1.60±0.20
Application	A	H	T1	C	d	D	W	E1	F
SOP-10	330.0±2.00	50 MIN.	12.4+2.00 -0.00	13.0+0.50 -0.20	1.5 MIN.	20.2 MIN.	12.0±0.30	1.75±0.10	5.5±0.05
	P0	P1	P2	D0	D1	T	A0	B0	K0
	4.0±0.10	8.0±0.10	2.0±0.05	1.5+0.10 -0.00	1.5 MIN.	0.6+0.00 -0.40	6.40±0.20	5.20±0.20	2.10±0.20

(mm)

### Devices Per Unit

Package Type	Unit	Quantity
TSSOP-14	Tape & Reel	2500
SOP-10	Tape & Reel	2500

## Taping Direction Information

TSSOP-14

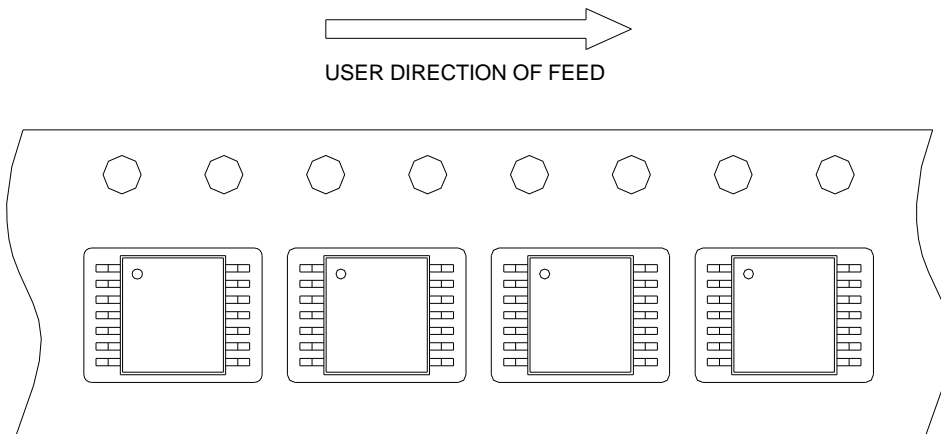

SOP-10

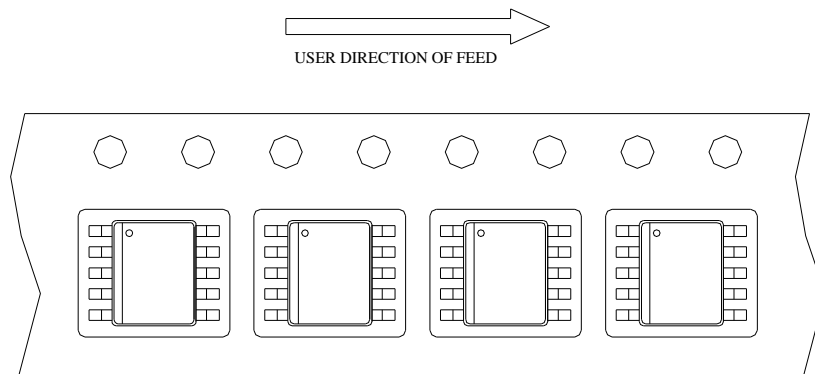

Classification Profile

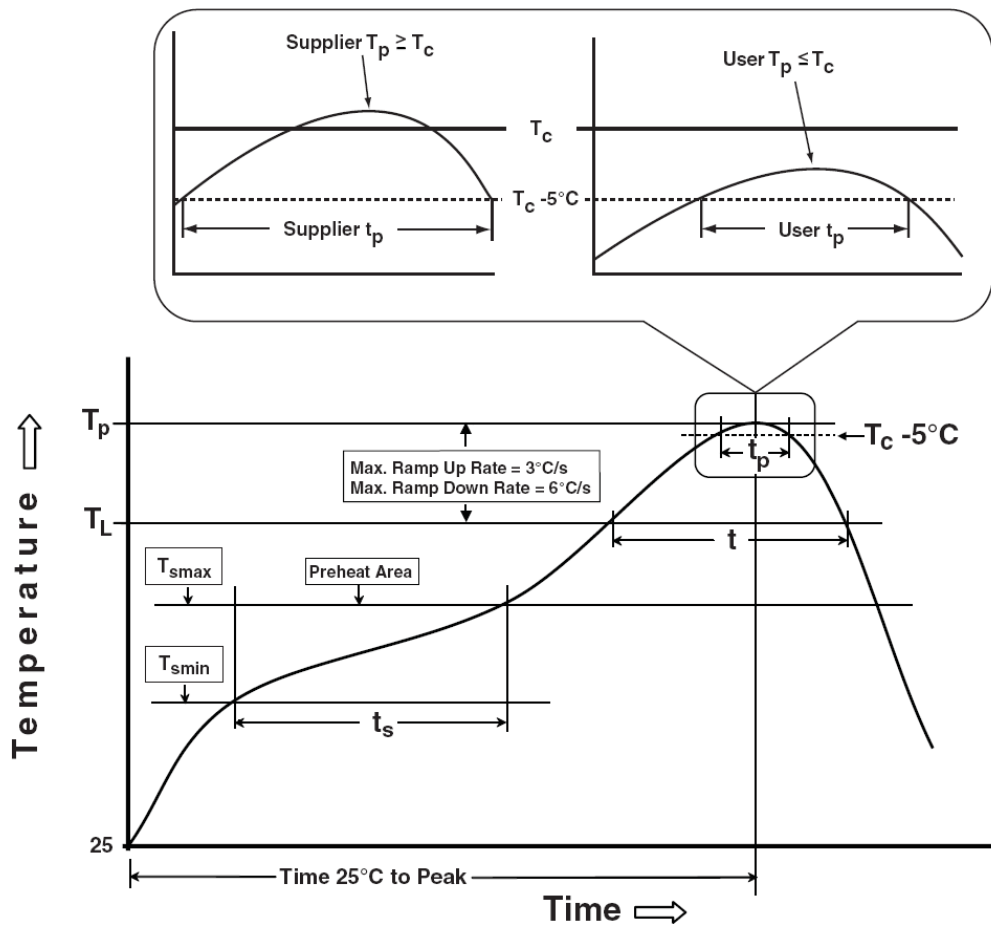

## Classification Reflow Profiles

Profile Feature	Sn-Pb Eutectic Assembly	Pb-Free Assembly
<b>Preheat &amp; Soak</b>		
Temperature min ( $T_{smin}$ )	100 °C	150 °C
Temperature max ( $T_{smax}$ )	150 °C	200 °C
Time ( $T_{smin}$ to $T_{smax}$ ) ( $t_s$ )	60-120 seconds	60-120 seconds
Average ramp-up rate ( $T_{smax}$ to $T_p$ )	3 °C/second max.	3°C/second max.
Liquidous temperature ( $T_L$ )	183 °C	217 °C
Time at liquidous ( $t_L$ )	60-150 seconds	60-150 seconds
Peak package body Temperature ( $T_p$ )*	See Classification Temp in table 1	See Classification Temp in table 2
Time ( $t_p$ )** within 5°C of the specified classification temperature ( $T_c$ )	20** seconds	30** seconds
Average ramp-down rate ( $T_p$ to $T_{smax}$ )	6 °C/second max.	6 °C/second max.
Time 25°C to peak temperature	6 minutes max.	8 minutes max.
* Tolerance for peak profile Temperature ( $T_p$ ) is defined as a supplier minimum and a user maximum.		
** Tolerance for time at peak profile temperature ( $t_p$ ) is defined as a supplier minimum and a user maximum.		

Table 1. SnPb Eutectic Process – Classification Temperatures ( $T_c$ )

Package Thickness	Volume mm <sup>3</sup> <350	Volume mm <sup>3</sup> ≥350
<2.5 mm	235 °C	220 °C
≥2.5 mm	220 °C	220 °C

Table 2. Pb-free Process – Classification Temperatures ( $T_c$ )

Package Thickness	Volume mm <sup>3</sup> <350	Volume mm <sup>3</sup> 350-2000	Volume mm <sup>3</sup> >2000
<1.6 mm	260 °C	260 °C	260 °C
1.6 mm – 2.5 mm	260 °C	250 °C	245 °C
≥2.5 mm	250 °C	245 °C	245 °C

## Reliability Test Program

Test item	Method	Description
SOLDERABILITY	JESD-22, B102	5 Sec, 245°C
HOLT	JESD-22, A108	1000 Hrs, Bias @ $T_j=125^\circ\text{C}$
PCT	JESD-22, A102	168 Hrs, 100%RH, 2atm, 121°C
TCT	JESD-22, A104	500 Cycles, -65°C~150°C
HBM	MIL-STD-883-3015.7	VHBM ≥ 2KV
MM	JESD-22, A115	VMM ≥ 200V
Latch-Up	JESD 78	10ms, $1_{tr} \geq 100\text{mA}$

---

## Customer Service

### **Anpec Electronics Corp.**

Head Office :

No.6, Dusing 1st Road, SBIP,  
Hsin-Chu, Taiwan  
Tel : 886-3-5642000  
Fax : 886-3-5642050

Taipei Branch :

2F, No. 11, Lane 218, Sec 2 Jhongsing Rd.,  
Sindian City, Taipei County 23146, Taiwan  
Tel : 886-2-2910-3838  
Fax : 886-2-2917-3838