

24V Single-Phase Full-Wave Motor Driver for Fan Motor

Features

- **Single-Phase Full Wave Fan Driver**
- **Low Supply Current**
- **Speed Controllable by DC Voltage or PWM Input Signal**
- **Built-in Quick Start Function**
- **Built-in Lock Protection and Auto-restart Function**
- **Enhance Low Duty Start UP Power**
- **FG/RDOutput**
- **Include Hall Bias Circuit**
- **Built-in Current Limit Circuit**
- **Built-in Thermal Protection Circuit**
- **TSSOP-16P Package**
- **Lead Free and Green Device Available (RoHS Compliant)**

General Description

The APX9221 is a single-phase full wave motor driver for DC fan motors. The output switch signals of this IC are PWM controlled. It is suitable for both game machine and CPU cooler that need silent fans. The device is built-in lock protection, when fan is locked, the device will enter the lockup protection mode. It is also with thermal shut-down function. In normal operation, the supply current is 3.5mA. The APX9221 is available in TSSOP-16P package.

Pin Configuration

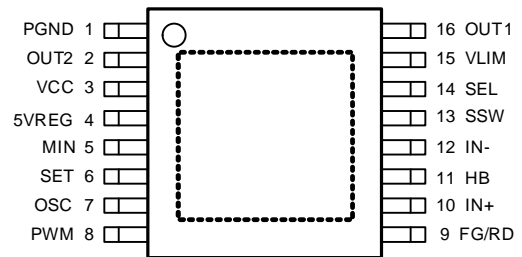

**TSSOP-16P
(Top View)**

 = Thermal Pad (connected to the GND plane for better heat dissipation)

Applications

- **CPU Cooler Fans**
- **Variable Speed Control Fans**

ANPEC reserves the right to make changes to improve reliability or manufacturability without notice, and advise customers to obtain the latest version of relevant information to verify before placing orders.

Ordering and Marking Information

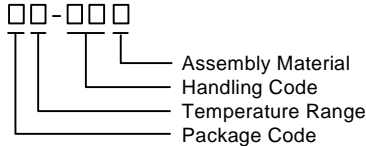
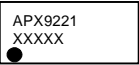
<p>APX9221</p>  <p>Assembly Material Handling Code Temperature Range Package Code</p>	<p>Package Code R:TSSOP - 16P Operating Ambient Temperature Range I : -40 to 110 °C Handling Code TR : Tape & Reel Assembly Material G: Halogen and Lead Free Device</p>
<p>APX9221 R :</p> 	<p>XXXXXX - Date Code</p>

Note: ANPEC lead-free products contain molding compounds/die attach materials and 100% matte tin plate termination finish; which are fully compliant with RoHS. ANPEC lead-free products meet or exceed the lead-free requirements of IPC/JEDEC J-STD-020D for MSL classification at lead-free peak reflow temperature. ANPEC defines "Green" to mean lead-free (RoHS compliant) and halogen free (Br or Cl does not exceed 900ppm by weight in homogeneous material and total of Br and Cl does not exceed 1500ppm by weight).

Absolute Maximum Ratings (Note 1)

Symbol	Parameter	Ratings	Unit
V _{CC}	VCC Pin Supply Voltage (VCC to GND)	-0.3 to 40	V
I _{OUT}	Output Pin Maximum Output Current	1.05	A
V _{OUT}	Output Pin Output Voltage	-0.3 to V _{CC}	V
I _{5VREG}	5VREG Pin Maximum Output Current	20	mA
I _{HB}	HB Pin Maximum Output Current	10	mA
V _{FG/RD}	FG/RD Pin Output Voltage	-0.3 to V _{CC}	V
I _{FG/RD}	FG/RD Pin Maximum Output Sink Current	10	mA
V _{PWM}	PWM Pin Input Voltage	-0.3 to V _{CC}	V
V _{SET}	SET Pin Input Voltage	-0.3 to 7	V
V _{MIN}	MIN Pin Input Voltage	-0.3 to 7	V
V _{VLM}	VLIM Pin Input Voltage	-0.3 to 7	V
V _{SEL}	SEL Pin Input Voltage	-0.3 to 7	V
V _{SSW}	SSW Pin Input Voltage	-0.3 to 7	V
T _J	Junction Temperature	-40 to 150	°C
T _{STG}	Storage Temperature	-65 to 150	°C
T _{SDR}	Maximum Lead Soldering Temperature (10 Seconds)	260	°C

Note1: Stresses beyond those listed under "absolute maximum ratings" may cause permanent damage to the device. These are stress ratings only and functional operation of the device at these or any other conditions beyond those indicated under "recommended operating conditions" is not implied. Exposure to absolute maximum rating conditions for extended periods may affect device reliability.

Thermal Characteristics

Symbol	Parameter	Typical Value	Unit
$R_{TH,JA}$	Thermal Resistance-Junction to Ambient ^(Note2) TSSOP-16P	83	°C/W
P_D	Power Dissipation, $T_A=25^{\circ}C$ TSSOP-16P	1.5	W

Note 2: $R_{TH,JA}$ is measured with the component mounted on a high effective thermal conductivity test board in free air.

Recommended Operating Conditions (Note3)

Symbol	Parameter	Range	Unit
V_{CC}	VCC Pin Supply Voltage Range	4 to 34	V
V_{HALL}	Hall Input Voltage Range	0.2 to 3	V
V_{SET}	SET Pin Input Voltage Range	0 to V_{5VREG}	V
V_{MIN}	MIN Pin Input Voltage Range	0 to V_{5VREG}	V
V_{VLIM}	VLIM Pin Input Voltage Range	0 to V_{5VREG}	V
V_{SSW}	SSW Pin Input Voltage Range	0 to V_{5VREG}	V
T_A	Ambient Temperature	-40 to 110	°C
T_J	Junction Temperature	-40 to 125	°C

Note 3: Refer to the typical application circuit.

Electrical Characteristics

($V_{CC} = 24V$, $T_A = 25^\circ C$, unless otherwise specified)

Symbol	Parameter	Test Conditions	APX9221			Unit
			Min	Typ	Max	
SUPPLY CURRENT						
V_{HB}	HB Pin Output Voltage	$I_{HB} = 5mA$	1.2	1.3	1.4	V
V_{5VREG}	5VREG Pin Output Voltage	$I_{5VREG} = 5mA$	4.75	5	5.25	V
I_{CC1}	Operating Current	Rotation Mode	2.5	4	5.5	mA
I_{CC2}		Lock Protection Mode	1.7	3.2	4.7	
OSCILLATOR						
V_{OSCH}	OSC Pin High Level Voltage		3.2	3.5	3.8	V
V_{OSCL}	OSC Pin Low Level Voltage		0.9	1	1.1	V
I_{OSC1}	OSC Charge Current	$V_{OSC} = 1V$	15	20	25	μA
I_{OSC2}	OSC Discharge Current	$V_{OSC} = 3.5V$	15	20	25	μA
F_{OSC}	OSC Oscillation Frequency	$C_{OSC} = 100pF$	30	40	50	kHz
LOCK PROTECTION						
T_{ON}	Lock Detection On Time		0.35	0.5	0.65	sec
T_{OFF}	Lock Detection OFF Time		3.5	5	6.5	sec
T_{QS}	Quick Start Enable Time		-	66.5	90	msec
OUTPUT DRIVERS						
V_O	Output Lower Side Saturation Voltage	$I_{OUT} = 300mA$, Upper and Lower total	-	0.4	0.6	V
V_{FG}	FG Pin Low Voltage	$I_{FG} = 5mA$	-	0.1	0.3	V
I_{FGL}	FG Pin Leakage Current	$V_{FG} = 24V$	-	<0.1	1	μA
PWM CONTROL						
V_{PVMH}	PWM Input High Level Voltage		2.5	-	$V_{CC} + 0.3$	V
V_{PWML}	PWM Input Low Level Voltage		-0.3	-	0.7	V
F_{PWM}	PWM Input Frequency		2	-	50	kHz
I_{PWM}	PWM Low Input Current	$V_{PWM} = 0V$	-	-10	-20	μA
SPEED CONTROL						
F_{OUT}	Output PWM Frequency		22	33	45	KHz
DTS	Start UP OUT PWM Duty		6	8	10	%

Electrical Characteristics (Cont.)

($V_{CC} = 24V$, $T_A = 25^{\circ}C$, unless otherwise specified)

Symbol	Parameter	Test Conditions	APX9221			Unit
			Min	Typ	Max	
HALL SENSITIVITY						
V_{HN}	FG Hall Input Sensitivity		-	10	20	mV
SWITCH OFF TIME CONTROL						
V_{Hys_ss}	Switch Hysteresis Voltage	$0V \leq SSW \leq 1V$ or floating	20	30	40	mV
		$SSW=2.5V$	60	75	90	mV
		$SSW=4V$	105	120	135	mV
CURRENT LIMIT						
I_{LM}	Current Limit	$V_{VLIM}=0\sim 0.5V$	-	150	-	mA
		$V_{VLIM}=3.5V$	-	1050	-	mA
THERMAL PROTECTION						
	Over-Temperature Shutdown Threshold		-	180	-	$^{\circ}C$
	Over-Temperature Shutdown Hysteresis		-	40	-	

Typical Operating Characteristics

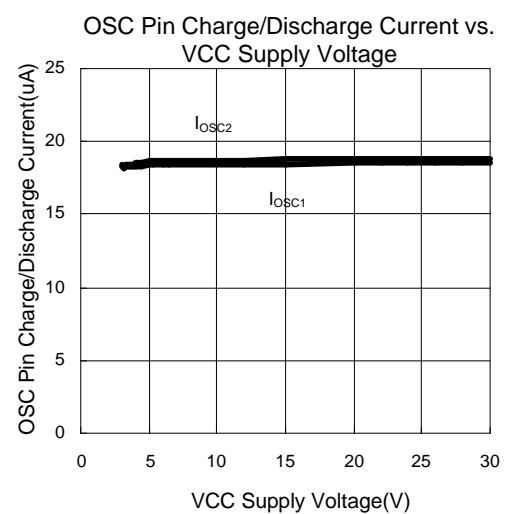
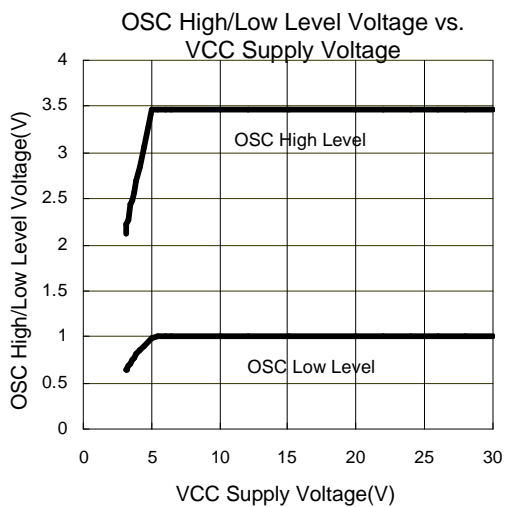
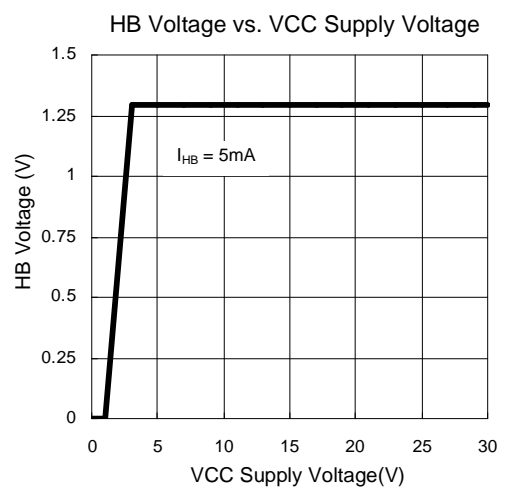
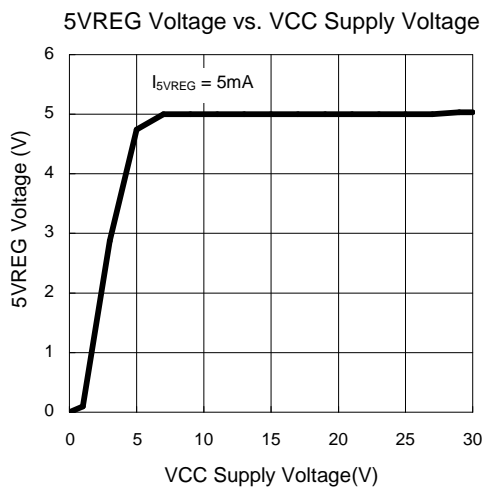
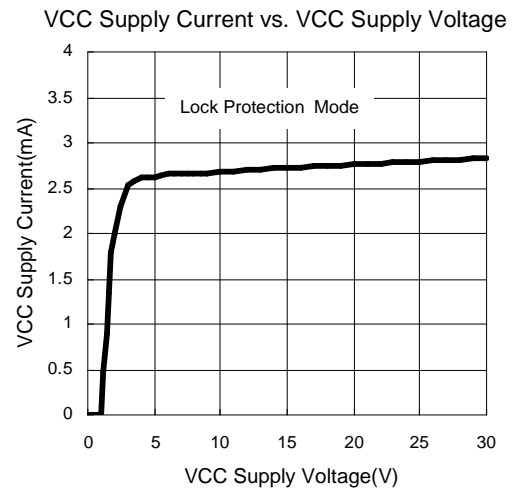
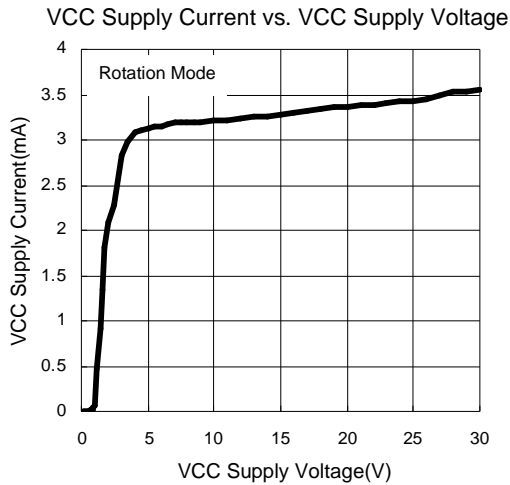

Typical Operating Characteristics (Cont.)

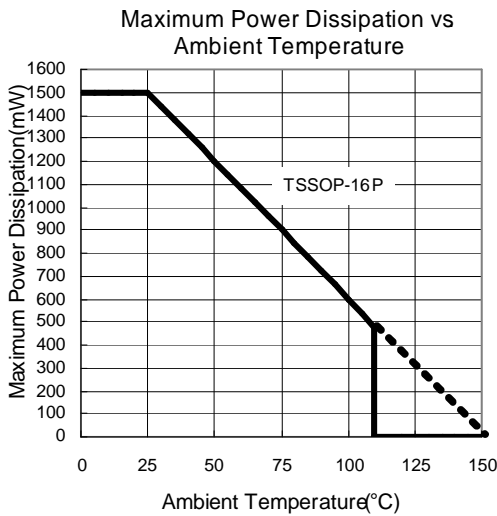
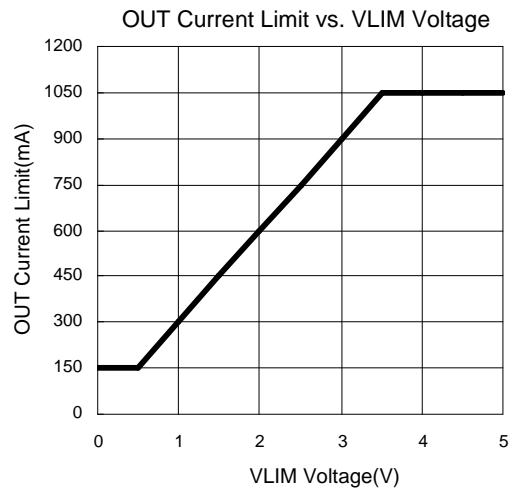
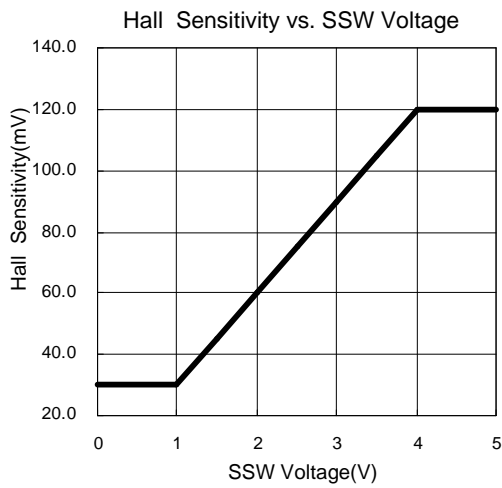
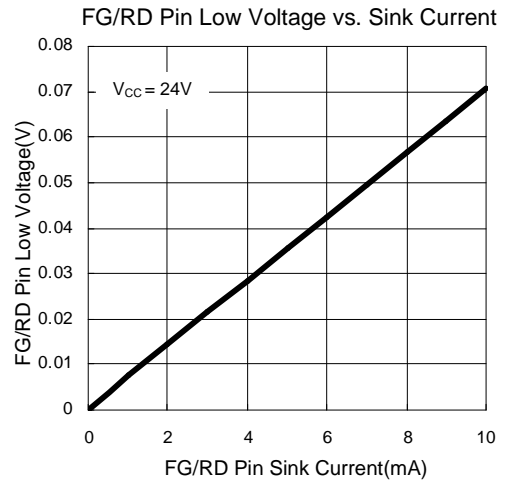
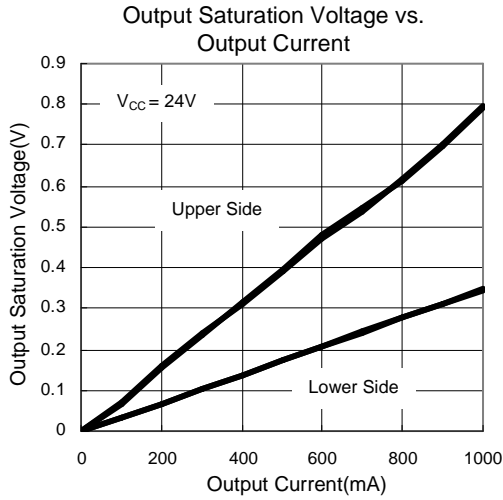

Pin Descriptions

PIN		FUNCTION
NO.	NAME	
1	PGND	Power Stage GND.
2	OUT2	H-bridge Output Connection.
3	VCC	Supply Voltage Input Pin.
4	5VREG	5V Regulator Output. This is a 5V constant-voltage output for application circuit biases.
5	MIN	Minimum Speed Setting. An external voltage into MIN pin to set fan speed.
6	SET	Speed Setting. An external voltage into SET pin to set fan speed.
7	OSC	Oscillation Frequency Setting. Connect a capacitor to GND to set oscillation frequency.
8	PWM	PWM Signal Input Terminal.
9	FG/RD	Rotation Speed Output/Rotation Detection Output.
10	IN+	Hall Input +. Connect to hall element positive output.
11	HB	Hall Bias. This is a 1.3V constant-voltage output for hall element bias.
12	IN-	Hall Input -. Connect to hall element negative output.
13	SSW	Voltage input pin for output switch off time control.
14	SEL	FG/RD output select pin.
15	VLIM	Current Limit Setting. Use a voltage divider from 5VREG to set VLIM pin voltage to set current limit value.
16	OUT1	H-bridge Output Connection.

Block Diagram

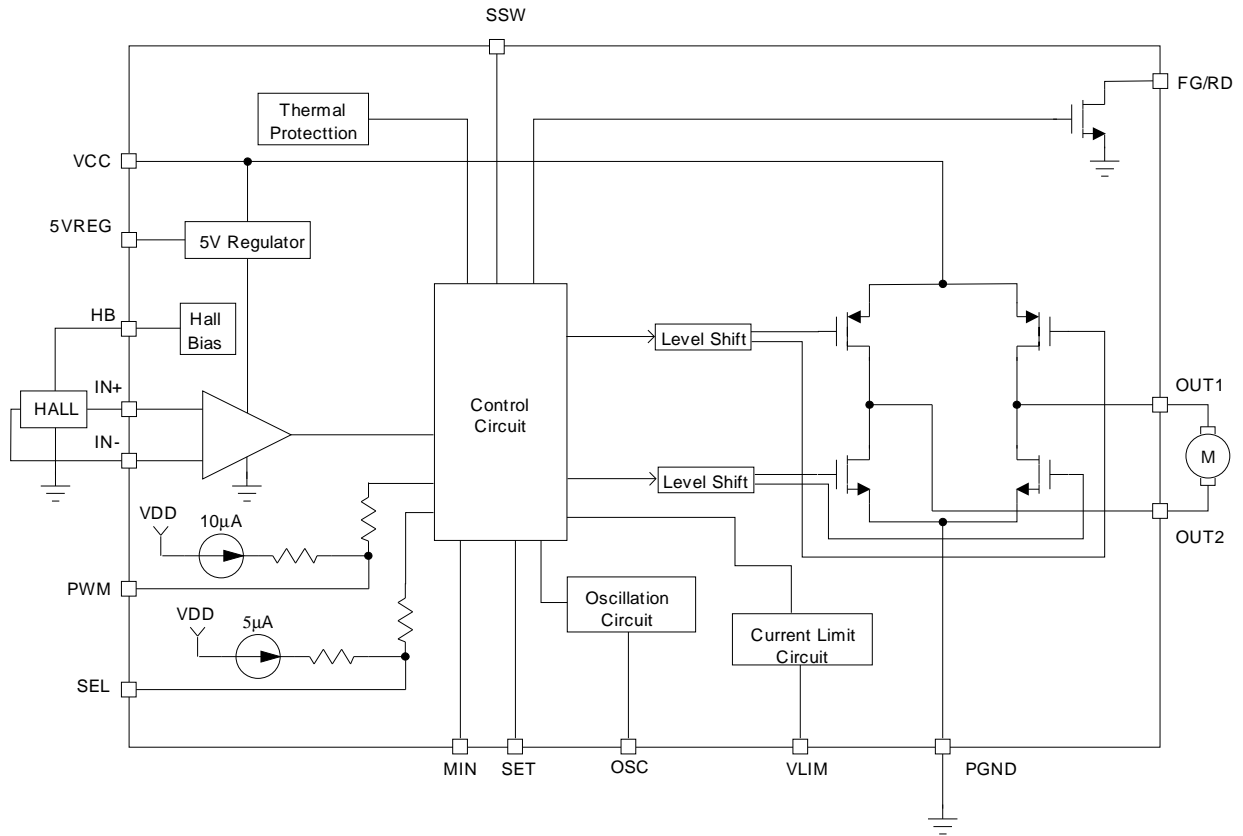

Typical Application Circuit

1. SET Voltage Input Speed Control

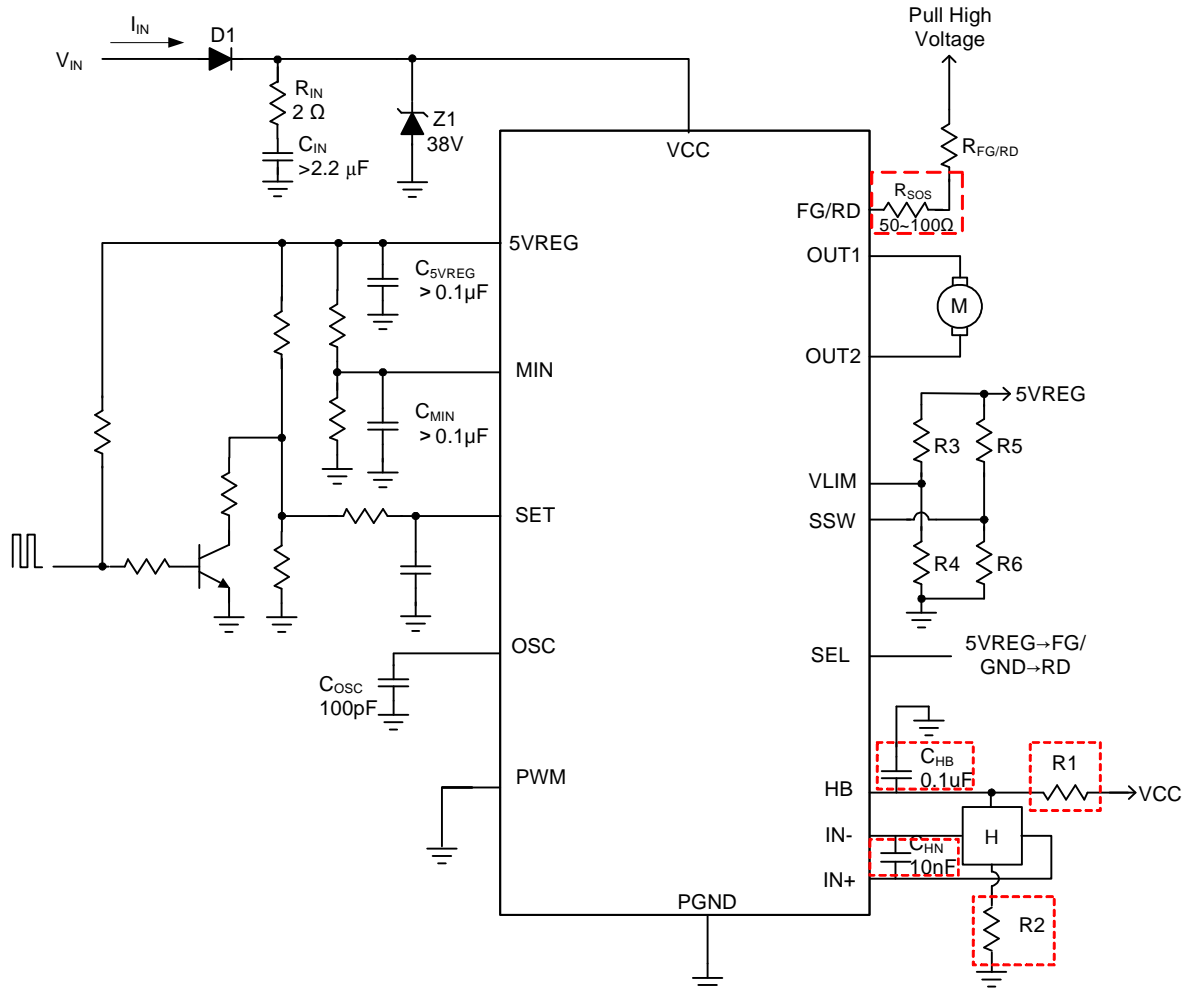

Note: R1 is optional to reduce the power consumption from HB supply current.
 R2 is optional to adjust the amplitude of Hall signal.
 C_{HN} is used to prevent noise coupling at power switch.
 C_{HB} is used to prevent destruction of Hall element.
 R_{SOS} is optional to protect internal circuit for abnormal voltage stress.
 When you do not use SSW pin, please connect to 5VREG or PGND pin.
 When you do not use VLIM pin, please connect to 5VREG or PGND pin.

Typical Application Circuit (Cont.)

2. Direct PWM Input Speed Control.

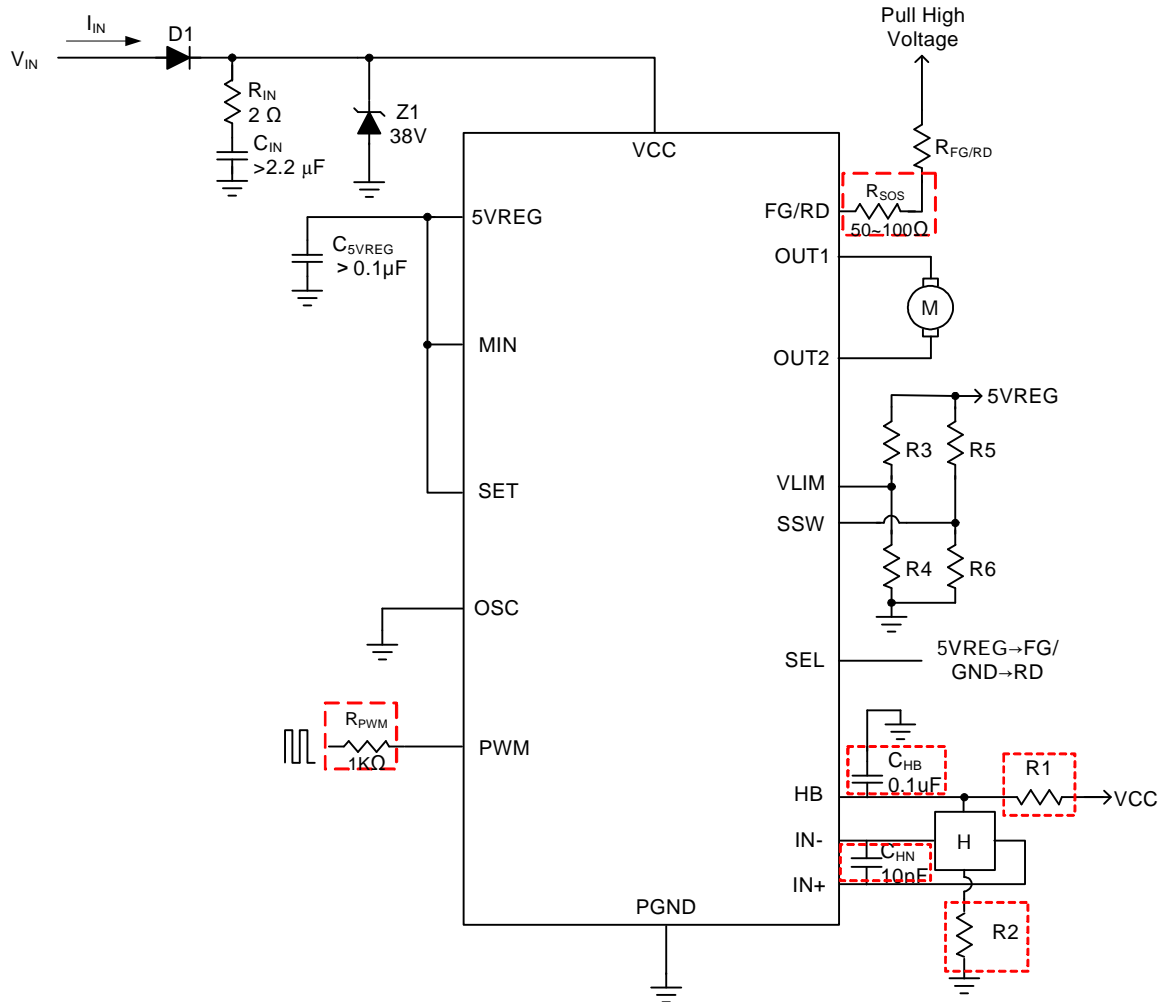

Note: R1 is optional to reduce the power consumption from HB supply current.
 R2 is optional to adjust the amplitude of Hall signal.
 C_{HN} is used to prevent noise coupling at power switch.
 C_{HB} is used to prevent destruction of Hall element.
 R_{PWM} and R_{SOS} are optional to protect internal circuit for abnormal voltage stress.
 When you do not use SSW pin, please connect to 5VREG or PGND pin.
 When you do not use VLIM pin, please connect to 5VREG or PGND pin.
 When you do not use PWM pin, please connect to 5VREG pin.

Function Descriptions

Lockup Protection and Automatic Restart

The APX9221 provides the lockup protection and automatic restart functions for preventing the coil burn-out when the fan is locked. This IC has an internal counter to determine the shutdown time (T_{OFF}) and restart time (T_{ON}). During shutdown time, the output drivers keep turn off for 5 seconds and then enter the restart time. During the restart time, one output is high and the other is low, which makes a torque for fan rotation. The restart time has 0.5 second. If the locked condition is not removed, the shutdown/restart process will be recurred until the locked condition is released (see Fig1. Lockup/Auto Restart Waveform).

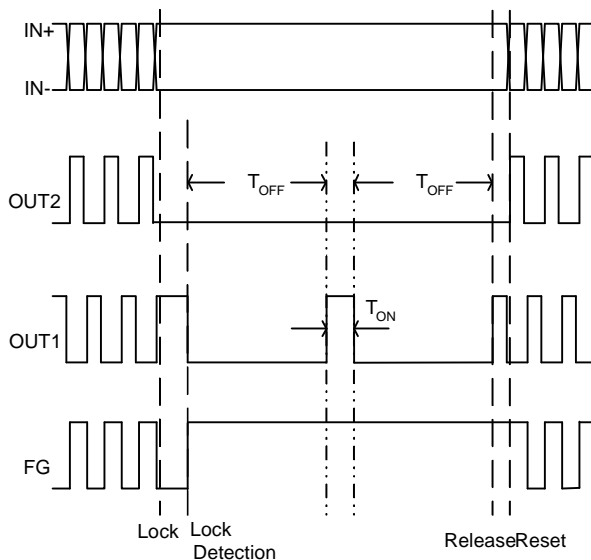

Figure 1. Lockup /Auto Restart Waveform

Quick Start and Standby mode

This IC would enter standby mode when the PWM input keeps low level for more than 66.5ms (typ.). In standby mode, it will shut down amplifier and FG. Thus, the supply current is around 3.2mA. In standby mode, the lock protection function doesn't work, therefore, starting fan is unobstructed when releasing standby mode.

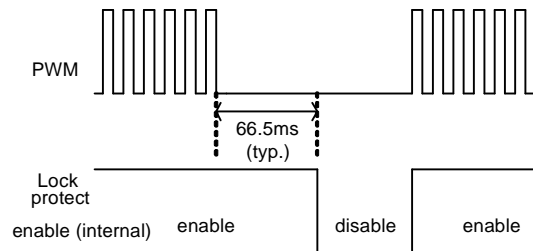

Figure 2. Quick Start Waveform

Variable Speed Control

The APX9221 has a variable speed controller. The speed is controlled by comparing the voltage of OSC, MIN and SET. The lowest speed drive duty is set by comparing the OSC oscillating voltage and MIN pin voltage when MIN pin voltage is lower than SET. When SET pin voltage is lower than MIN, PWM control system works by comparing the voltage of SET and OSC. When SET pin voltage is lower than OSC, upper and lower side's transistors are ON. When SET pin voltage is higher than OSC, upper side transistors are OFF and coil current re-circulates lower side transistor. The lower SET pin voltage is, the more output ON duty will be. Hence, the coil current will be enlarged and motor speed will be faster. Rotation speed is able to feedback by FG output. The Output PWM frequency is fixed at 33 KHz. (See Figure 3. Rotation Waveform).

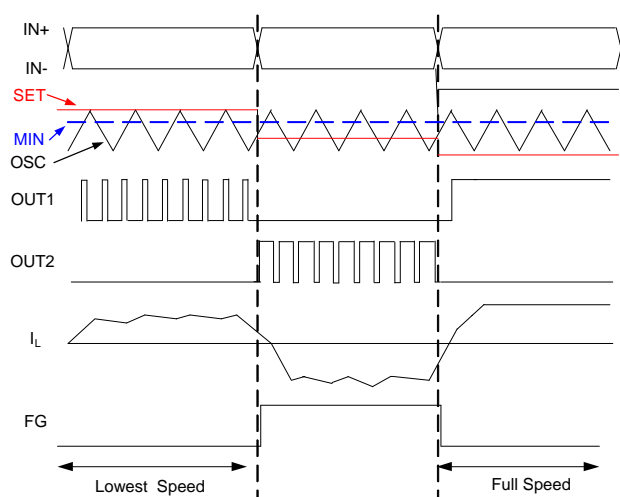

Figure 3. Rotation Waveform

Function Descriptions (Cont.)

PWM and SET Control

The APX9221 also support direct PWM input signal and SET input voltage speed control. When the MIN pin pulled up to 5VREG, the PWM and SET input pin to control the output duty directly. The DTS rang is between OUT PWM Duty 6% and 10%.

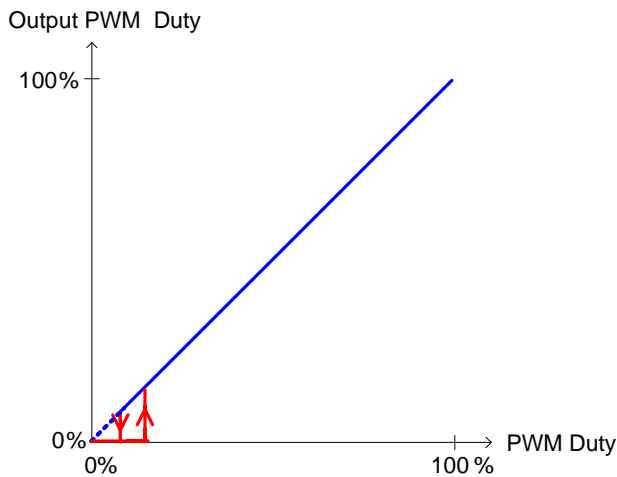

Figure 4. PWM mode

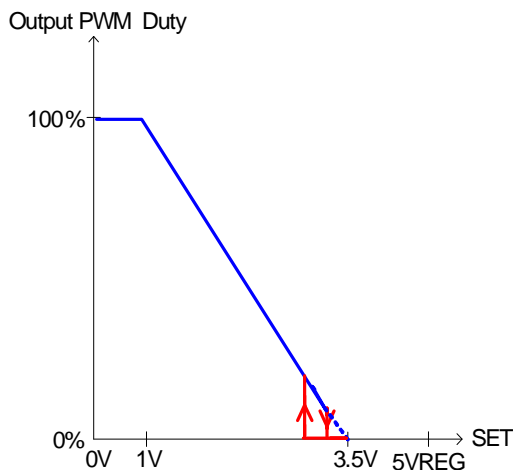

Figure 5. SET mode

Output Drivers

All four drivers in the bridge output are designed for single phase full wave motor driver for fan motor. The linear output architecture is used as output driver.

Rotation Detection Function

The FG pin is an open drain output, connecting a pull up resistor to a high level voltage for the frequency generator function. When IN+ is larger than IN- then FG is high (switch off) and IN+ is smaller than IN- then FG is low (switch on). Open the terminal when not in using. RD pin is also open drain output. Low level is at rotation mode and High Level is at stop mode.

Thermal Protection

The APX9221 has thermal protection function, when internal junction temperature reaches 180°C, the output devices will be switched off. When the IC's junction temperature cools by 40°C, the thermal sensor will turn the output devices on again, resulting in a pulsed output during continuous thermal protection.

Truth Table

Input				Output				Mode
IN-	IN+	OSC	PWM	OUT1	OUT2	FG	RD	
H	L	H	H	H	L	L	L	Normal Operation Mode
L	H			L	H	OFF	L	
L	H	L	L	L	L	OFF	L	
H	L			L	L	L	L	
H	L	-	-	L	L	OFF	OFF	Lock Protection Mode
L	H			L	L	OFF		
-	-	-	L	OFF	OFF	OFF	OFF	Standby Mode

Note 4: OSC-H corresponds to $V_{OSC} > V_{SET}$ and OSC-L corresponds to $V_{OSC} < V_{SET}$

Application Information

Input Protection Diode & Capacitor

It should be added a protection diode (D1) to protect the damage from the power reverse connection. However, the protection diode will cause a voltage drop on the supply voltage. The current rating of the diode must be larger than the maximum output current. For the noise reduction purpose, there is a least 2.2μF capacitor (C_{IN}) recommended connecting between VCC and GND (see Typical Application Circuit).

FG/RD Resistor

The value of the FG/RD resistor could be decided by the following equation:

$$R_{FG} = \frac{V_{CC} - V_{FG}}{I_{FG}}$$

For example:

$$V_{CC}=24V, I_{FG}=5mA, V_{FG}=0.1V, R_{FG}=4.78k\Omega$$

The value of resistor in the range of 1kΩ to 10kΩ is recommended.

Adjustment of output switch off time control

The output off time before and after switching is controlled by SSW voltage. The voltage range is between 1V to 4V . Normal adjustment voltage of SSW between hall input signals. (see Fig.6) When input signal amplitude is less V_{hys_ss} IC is not operate properly. (see Fig.7)

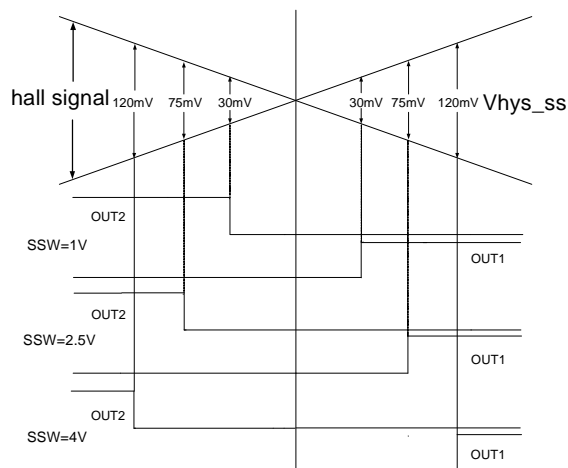

Figure 6. When hall signal > V_{hys_ss}.

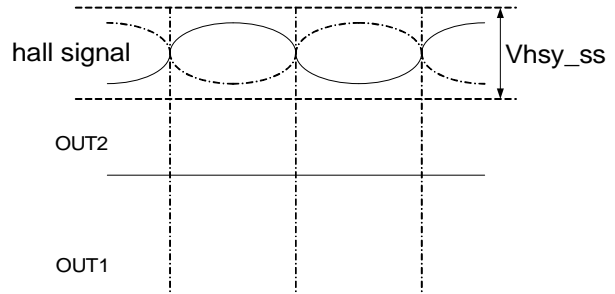
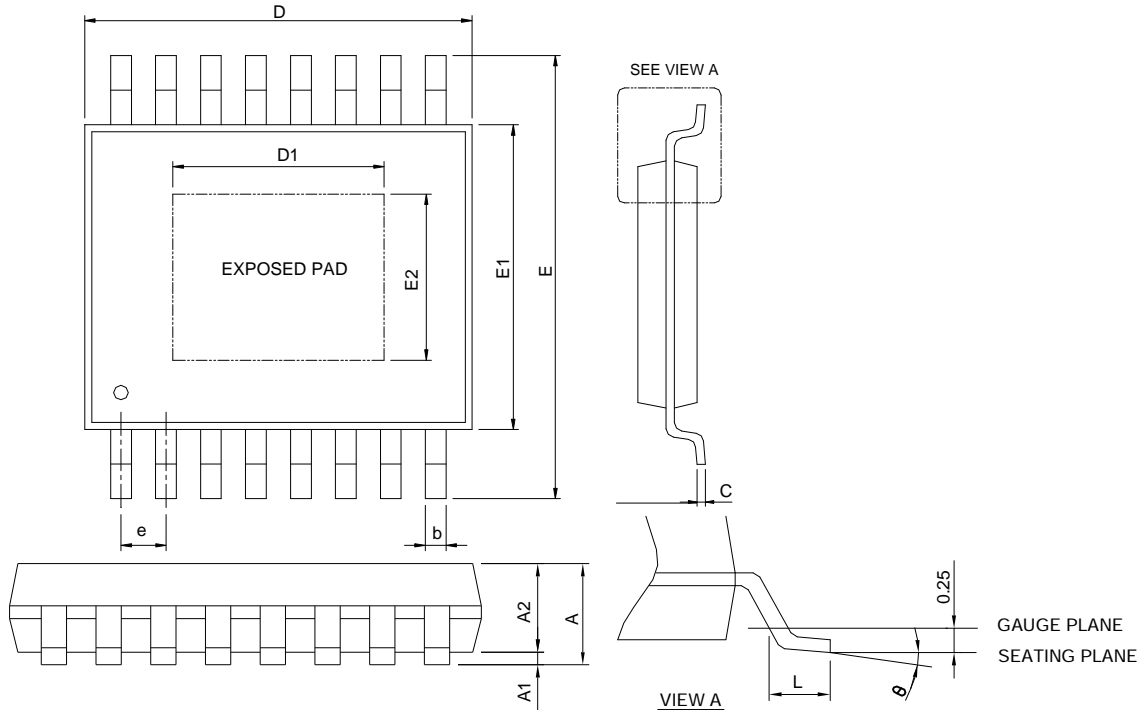

Figure 7. When hall signal < V_{hys_ss}. IC does not operate properly.

Package Information

TSSOP-16P



SYMBOL	TSSOP-16P			
	MILLIMETERS		INCHES	
	MIN.	MAX.	MIN.	MAX.
A		1.20		0.047
A1	0.05	0.15	0.002	0.006
A2	0.80	1.05	0.031	0.041
b	0.19	0.30	0.007	0.012
c	0.09	0.20	0.004	0.008
D	4.90	5.10	0.193	0.201
D1	2.00	3.50	0.079	0.138
E	6.20	6.60	0.244	0.260
E1	4.30	4.50	0.169	0.177
E2	2.50	3.50	0.098	0.138
e	0.65 BSC		0.026 BSC	
L	0.45	0.75	0.018	0.030
θ	0°	8°	0°	8°

- Note : 1. Follow from JEDEC MO-153 AB.
 2. Dimension "D" does not include mold flash, protrusions or gate burrs. Mold flash, protrusion or gate burrs shall not exceed 6 mil per side.
 3. Dimension "E1" does not include inter-lead flash or protrusions. Inter-lead flash and protrusions shall not exceed 10 mil per side.

Carrier Tape & Reel Dimensions

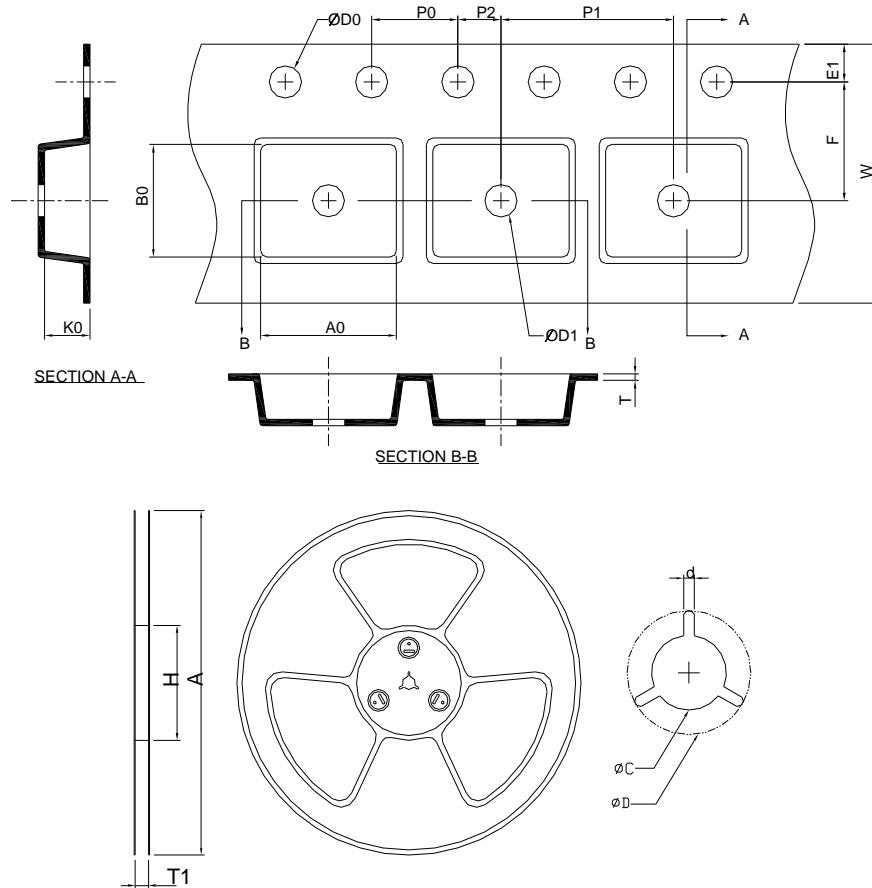

Application	A	H	T1	C	d	D	W	E1	F
TSSOP-16P	330.0±2.00	50 MIN.	12.4+2.00 -0.00	13.0+0.50 -0.20	1.5 MIN.	20.2 MIN.	12.0±0.30	1.75±0.10	5.50±0.05
	P0	P1	P2	D0	D1	T	A0	B0	K0
	4.00±0.10	8.00±0.10	2.00±0.05	1.5+0.10 -0.00	1.5 MIN.	0.6+0.00 -0.40	6.80±0.20	5.40±0.20	1.60±0.20

(mm)

Devices Per Unit

Package Type	Unit	Quantity
TSSOP- 16P	Tape & Reel	2500

Taping Direction Information

TSSOP-16P

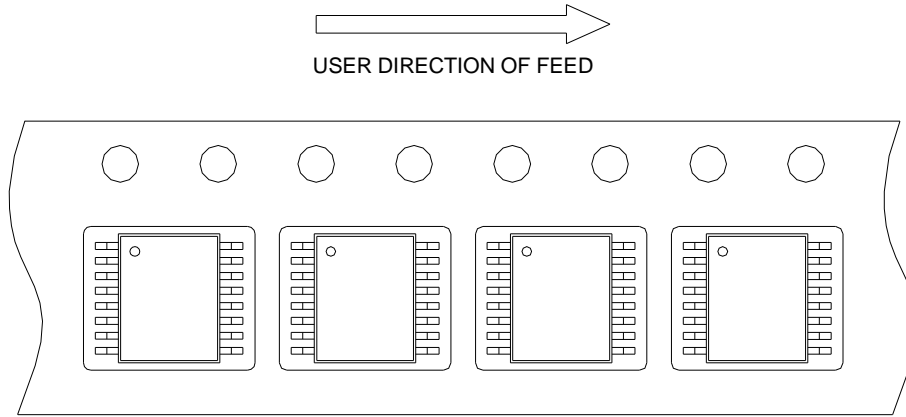

Classification Profile

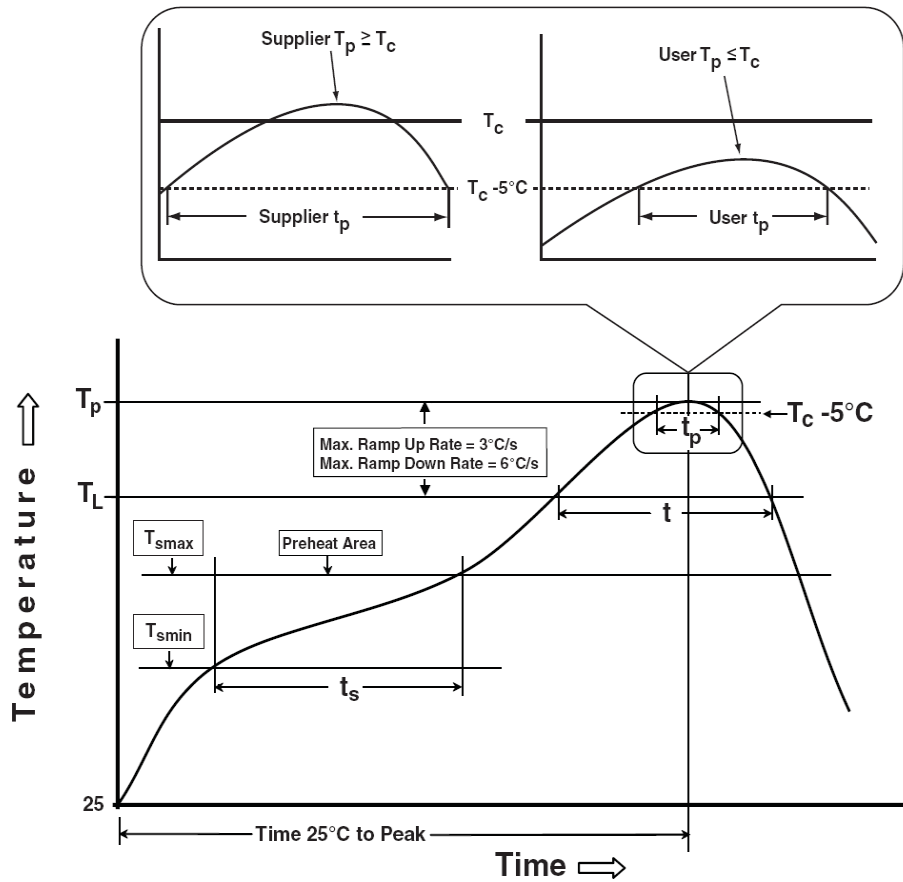

Classification Reflow Profiles

Profile Feature	Sn-Pb Eutectic Assembly	Pb-Free Assembly
Preheat & Soak		
Temperature min (T_{smin})	100 °C	150 °C
Temperature max (T_{smax})	150 °C	200 °C
Time (T_{smin} to T_{smax}) (t_s)	60-120 seconds	60-120 seconds
Average ramp-up rate (T_{smax} to T_p)	3 °C/second max.	3°C/second max.
Liquidous temperature (T_L)	183 °C	217 °C
Time at liquidous (t_L)	60-150 seconds	60-150 seconds
Peak package body Temperature (T_p)*	See Classification Temp in table 1	See Classification Temp in table 2
Time (t_p)** within 5°C of the specified classification temperature (T_c)	20** seconds	30** seconds
Average ramp-down rate (T_p to T_{smax})	6 °C/second max.	6 °C/second max.
Time 25°C to peak temperature	6 minutes max.	8 minutes max.
* Tolerance for peak profile Temperature (T_p) is defined as a supplier minimum and a user maximum.		
** Tolerance for time at peak profile temperature (t_p) is defined as a supplier minimum and a user maximum.		

Table 1. SnPb Eutectic Process – Classification Temperatures (T_c)

Package Thickness	Volume mm ³ <350	Volume mm ³ ≥350
<2.5 mm	235 °C	220 °C
≥2.5 mm	220 °C	220 °C

Table 2. Pb-free Process – Classification Temperatures (T_c)

Package Thickness	Volume mm ³ <350	Volume mm ³ 350-2000	Volume mm ³ >2000
<1.6 mm	260 °C	260 °C	260 °C
1.6 mm – 2.5 mm	260 °C	250 °C	245 °C
≥2.5 mm	250 °C	245 °C	245 °C

Reliability Test Program

Test item	Method	Description
SOLDERABILITY	JESD-22, B102	5 Sec, 245°C
HOLT	JESD-22, A108	1000 Hrs, Bias @ $T_j=125^\circ\text{C}$
PCT	JESD-22, A102	168 Hrs, 100%RH, 2atm, 121°C
TCT	JESD-22, A104	500 Cycles, -65°C~150°C
HBM	MIL-STD-883-3015.7	VHBM ≥ 2KV
MM	JESD-22, A115	VMM ≥ 200V
Latch-Up	JESD 78	10ms, $1_{tr} \geq 100\text{mA}$

Customer Service

Anpec Electronics Corp.

Head Office :

No.6, Dusing 1st Road, SBIP,
Hsin-Chu, Taiwan
Tel : 886-3-5642000
Fax : 886-3-5642050

Taipei Branch :

2F, No. 11, Lane 218, Sec 2 Jhongsing Rd.,
Sindian City, Taipei County 23146, Taiwan
Tel : 886-2-2910-3838
Fax : 886-2-2917-3838